

# **PowerBoss®**

## **SCV 28/32 RIDER SCRUBBER**

**OPERATION ■ SERVICE ■ PARTS ■ CARE**



# PowerBoss®

This manual is furnished with each new **POWERBOSS SCV™ 28/32**. This provides the necessary operating and preventive maintenance instructions. Operators must read and understand this manual before operating or servicing this machine.

This machine was designed to give you excellent performance and efficiency. For best results and minimal cost, please follow the general guidelines below:

- Operate the machine with reasonable care.
- Follow the manufacturers suggested maintenance instructions as provided in this booklet.
- Use original Minuteman supplied parts.

## TECHNICAL SPECIFICATIONS

<b>Model</b>	<b>SCV™28/32</b>
Model No.	PB280000QP / PB280001QP / PB32000QP / PB320001QP PB280000CE / PB280001CE / PB320000CE / PB320001CE
Current	65 Amps
Voltage, Batteries	36 volts, 6-6volt
Battery Capacity	370 AH
Sound Level	72dB
Dimensions (LxWxH)	34" x 31" x 54" (160cm x 78.74cm x 137cm)
Gross Weight	1,495 lbs (678 kg) with batteries 793 lbs (360 kg) without batteries
Working Grade Transport	16% (10°)
Working Grade Cleaning	10% (7°)
Wheel to Floor Pressure	64 PSI Front, 69 PSI Rear

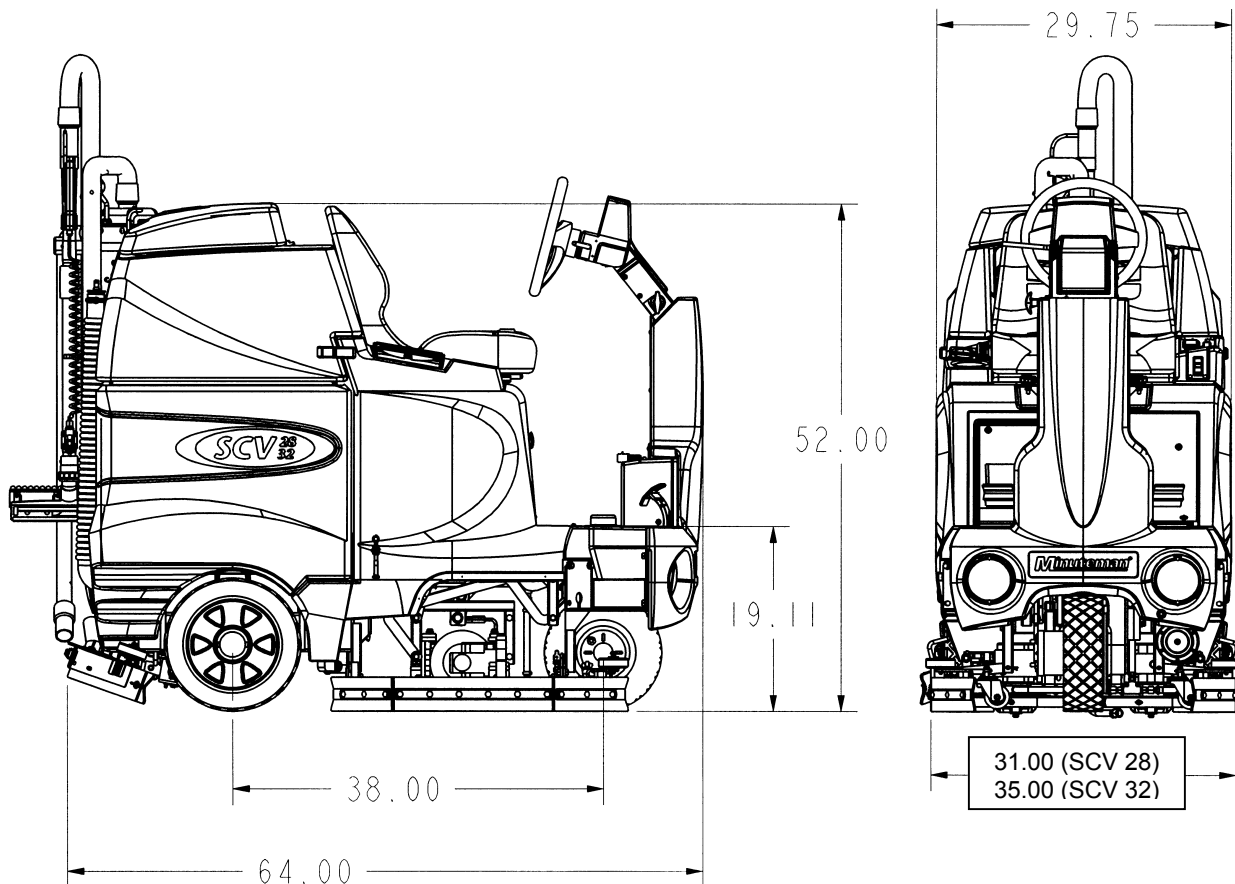

# EC Declaration of Conformity

according to Directives 72/23, 89/392, and 89/336

We, Minuteman International Incorporated, of 111 South Rohlwing Road Addison Illinois 60101 USA, declare under our sole responsibility that the product SCV 28/32, PB280000CE, PB280001CE, PB320000CE, PB320001CE, to which this declaration relates corresponds to the relevant requirements of the EC Directives 72/23, 89/392 and 89/336. The following standards were used to determine compliance with the Directives: EN 292, EN 294, EN 811, EN 55014, EN 55104 and IEC 335-1-72.

SOUND		VIBRATION												
<b>75 dB Operator</b>	<b>72 dB At 3m</b>	<b>.4 m/s<sup>2</sup> At Operators Handle</b>												
Tests were conducted on 7/15/02 with calibrated sound and vibration equipment under the conditions noted below: <table style="width: 100%; margin-top: 10px;"> <tr> <td style="width: 33%;">General Condition:</td> <td style="width: 33%;">Indoors</td> <td style="width: 33%;">Wind:</td> <td style="width: 33%;">0 km/hr</td> </tr> <tr> <td>Temperature:</td> <td>23<sup>o</sup>C</td> <td>Humidity:</td> <td>70%</td> </tr> <tr> <td>Barometric Pressure:</td> <td>29.1</td> <td></td> <td></td> </tr> </table>			General Condition:	Indoors	Wind:	0 km/hr	Temperature:	23 <sup>o</sup> C	Humidity:	70%	Barometric Pressure:	29.1		
General Condition:	Indoors	Wind:	0 km/hr											
Temperature:	23 <sup>o</sup> C	Humidity:	70%											
Barometric Pressure:	29.1													

Jeff Pollack

---

Jeff Pollack, Standards Engineer

Nov. 22, 2002

---

Date

**TABLE OF CONTENTS**  
**Operation, Illustration, Spare Parts, and Maintenance**

<b>IMPORTANT SAFETY INSTRUCTIONS</b> .....1	EMPTY SOLUTION TANK INDICATOR . 6
FOR SAFETY DURING OPERATION: .....1	RECOVERY TANK FULL INDICATOR...6
FOR SAFETY WHEN SERVICING OR	LOW BATTERY INDICATOR..... 7
MAINTAINING MACHINE: .....1	DIAGNOSTIC CODE..... 7
<b>INSPECTION</b> .....1	FAULT / DIAGNOSTIC CODE ..... 7
<b>ELECTRICAL</b> .....1	OPERATION OF CONTROLS ..... 8
<b>BATTERIES</b> .....1	POWER SAVE MODE..... 8
<b>OPERATOR RESPONSIBILITY</b> .....1	ACCELERATOR PEDAL ..... 8
<b>MACHINE COMPONENTS</b> .....1	SEAT ..... 8
<b>FRONT</b> .....1	STEERING WHEEL ..... 8
<b>MACHINE COMPONENTS</b> .....2	MECHANICAL & PARKING BRAKE..... 9
<b>REAR</b> .....2	EMERGENCY DISCONNECT BUTTON 9
<b>MACHINE COMPONENTS</b> .....2	CIRCUIT BREAKERS ..... 9
<b>DRIVER'S COMPARTMENT</b> .....2	BATTERY COMPARTMENT..... 10
CONTROL CONSOLE .....3	SCRUB DECK ..... 11
Key switch.....3	CYLINDRICAL..... 11
Off-aisle wand switch.....3	SCRUB DECK..... 11
Headlight switch.....3	DISC SCRUB DECK ..... 11
Main Keyboard.....3	SCRUB DECK INSTALLATION ..... 12
Horn button .....3	SIDE SQUEEGEE ..... 13
Directional switch.....3	REAR SQUEEGEE ..... 14
MAIN KEYBOARD .....4	REAR SQUEEGEE COMPONENTS .... 14
FULL FUNCTION MODE.....4	REAR SQUEEGEE ADJUSTMENT .... 15
DOUBLE SCRUB MODE.....4	OFF-AISLE WAND..... 15
VACUUM ONLY MODE.....4	OFF-AISLE WAND TOOL..... 16
TRANSPORT MODE.....4	<b>THE SCV RIDER</b> ..... 17
INFORMATION BUTTON.....4	MACHINE OPERATION..... 17
WATER FLOW ADJUSTMENT .....5	AFTER USE: ..... 19
BRUSH PRESSURE ADJUSTMENT .....5	MAINTENANCE SCHEDULE..... 20
EMPTY SOLUTION TANK INDICATOR..5	LUBRICATING THE MACHINE ..... 20
RECOVERY TANK FULL INDICATOR ...5	GENERAL MACHINE
LCD DISPLAYS.....5	TROUBLESHOOTING ..... 21
INFORMATION BUTTON.....5	<b>SCV 28/32 FAULT / DIAGNOSTIC CODES</b> . 23
DIRECTIONAL SWITCH FORWARD.....5	<b>EXPLODED VIEWS</b> ..... 25
DIRECTIONAL SWITCH REVERSE .....5	MAIN ASSEMBLY I ..... 25
FULL FUNCTION MODE.....6	MAIN ASSEMBLY II ..... 27
DOUBLE SCRUB MODE.....6	MAINFRAME ASSEMBLY I..... 29
VACUUM ONLY MODE.....6	FRONT DRIVE ASSEMBLY..... 32
TRANSPORT MODE.....6	STEERING ASSEMBLY ..... 34
BRUSH PRESSURE ADJUSTMENT .....6	SOLUTION TANK ASSEMBLY ..... 36
WATER FLOW ADJUSTMENT .....6	SOLUTION TANK ASSEMBLY II ..... 38
	CONSOLE ASSEMBLY..... 40
	RECOVERY TANK ASSEMBLY I ..... 41
	RECOVERY TANK II..... 43
	DIVERter ASSEMBLY ..... 44
	BATTERY BOX ASSEMBLY ..... 45
	PUMP ASSEMBLY ..... 46
	REAR AXLE ASSEMBLY ..... 48
	SQUEEGEE MECHANISM ASSEMBLY ... 49
	REAR SQUEEGEE ASSEMBLY 28"..... 50

REAR SQUEEGEE ASSEMBLY 32" .....	52
28" CYLINDRICAL SCRUB DECK ASSEMBLY .....	54
28" CYLINDRICAL SCRUB DECK ASSEMBLY .....	54
28" DISC SCRUB DECK ASSEMBLY .....	56
32" CYLINDRICAL SCRUB DECK ASSEMBLY .....	58
32" DISC SCRUB DECK ASSEMBLY .....	60
CYLINDRICAL DECK AND SIDE SQUEEGEE MOUNTING .....	62
DISC SCRUBDECK AND SIDE SQUEEGEE MOUNTING .....	64
28" SIDE SQUEEGEE (RIGHT SIDE) .....	66
28" SIDE SQUEEGEE (LEFT SIDE).....	67
32" SIDE SQUEEGEE (LEFT SIDE).....	69
OFF AISLE WAND ASSEMBLY .....	70
<b>PLUMBING DIAGRAM .....</b>	<b>72</b>
<b>WIRING DIAGRAMS.....</b>	<b>73</b>
INPUTS TO CONTROLLER .....	74
OUTPUTS FROM CONTROLLER.....	75
KEYBOARD WIRING .....	76
MACHINE SCHEMATIC.....	77

## IMPORTANT SAFETY INSTRUCTIONS

**Operators must read and understand this manual before operating or maintaining this machine. Do not operate this machine in flammable or explosive areas.**

This machine is designed solely for scrubbing dirt and dust in an indoor environment. Minuteman does not recommend using this machine in any other capacity.

The following information below may cause a potential hazard to the operator and equipment. Read this manual carefully and be aware when these conditions can exist. Take necessary steps to locate all safety devices on the machine and train the personnel operating the machine. Report any machine damage or faulty operation immediately. **Do not use machine if it is not in proper operating condition.**

### **FOR SAFETY DURING OPERATION:**

Keep hands and feet clear of moving parts while machine is in operation.

Make sure all safety devices are in place and operate properly. All covers, doors and latches must be closed and fastened before use.

During operation, attention should be paid to other persons in the work area and especially if small children are present.

Electric motors and components can cause an explosion when operated near explosive materials or vapor. Do not operate this machine near flammable materials such as solvents, thinners, fuels, grain dust, etc.

Store or park this machine on a level surface only, with parking brake engaged. To prevent unauthorized use, machine should be stored or parked with the key removed.

This machine is designed for level operation only. **Do not operate on ramps or inclines.**

This machine is not suitable for picking up hazardous dusts.

Use caution when moving this machine into areas that are below freezing temperatures. Any water in the tanks or hoses can cause damage to the machine.

### **FOR SAFETY WHEN SERVICING or MAINTAINING MACHINE:**

Stop on level surface and set parking brakes.

Disconnect the power to the machine by pressing the Red Emergency Disconnect Button when charging batteries or during installation or removal of brushes.

Avoid moving parts. Do not wear loose jackets, shirts, or sleeves when working on machine.

Avoid contact with battery acid. Battery acid can cause burns. When working on or around batteries, wear protective clothing and safety glasses. Remove metal jewelry. Do not lay tools or metal objects on top of batteries.

Charging batteries generates explosive gasses. **Do not charge batteries when open flames or sparks are present. Do not smoke.** Make sure the charger is turned off before disconnecting it from the machine. Charge the batteries in a well-ventilated area with the battery cover removed completely.

Do not clean machine with a pressure washer.

Authorized personnel must perform repairs and maintenance. Use Minuteman supplied replacement parts.

**SAVE THESE INSTRUCTIONS**

## INSPECTION

Carefully unpack and inspect your **SCV Rider Scrubber** for shipping damage. Follow unpacking instructions on shipping pallet. Each unit has been tested and thoroughly inspected before shipment. Any damage is the responsibility of the delivery carrier who should be notified immediately.

## ELECTRICAL

This machine is battery operated and designed to operate on 36 volts DC (6) 6-volt batteries.

## BATTERIES

The recommended batteries are rated 370Ah (Minuteman P/N 956715).

*We do not recommend mixing AMP hour capacities. Any alternate battery sets can be used if they equal physical size and capacity. See page 13 for service and installation.*

## OPERATOR RESPONSIBILITY

Read this manual carefully before operating this machine.

The operator is responsible in taking care of the daily maintenance and check ups of the machine to keep it in good working condition. The operator must inform the service mechanic or supervisor when the scheduled maintenance intervals are required as stated in the *MAINTENANCE* section of this manual.

Before starting familiarize yourself with the machine and its controls (see "Machine Overview, Front", "Machine Overview, Rear", "Operator Compartment", "Control Console" diagrams).

## MACHINE COMPONENTS FRONT

A	Front drive wheel
B	Side squeegee
C	Headlights
D	Accelerator pedal
E	Tilt-wheel lever
F	Steering wheel
G	Operator's seat
H	Recovery tank lid
I	Recovery tank
J	Control console
K	Directional switch
L	Safety latch
M	Battery compartment
N	Solution tank
O	Electrical panel
P	Parking brake
Q	Rear Squeegee
R	Rear wheel
S	Scrub deck
T	Roller Bumpers

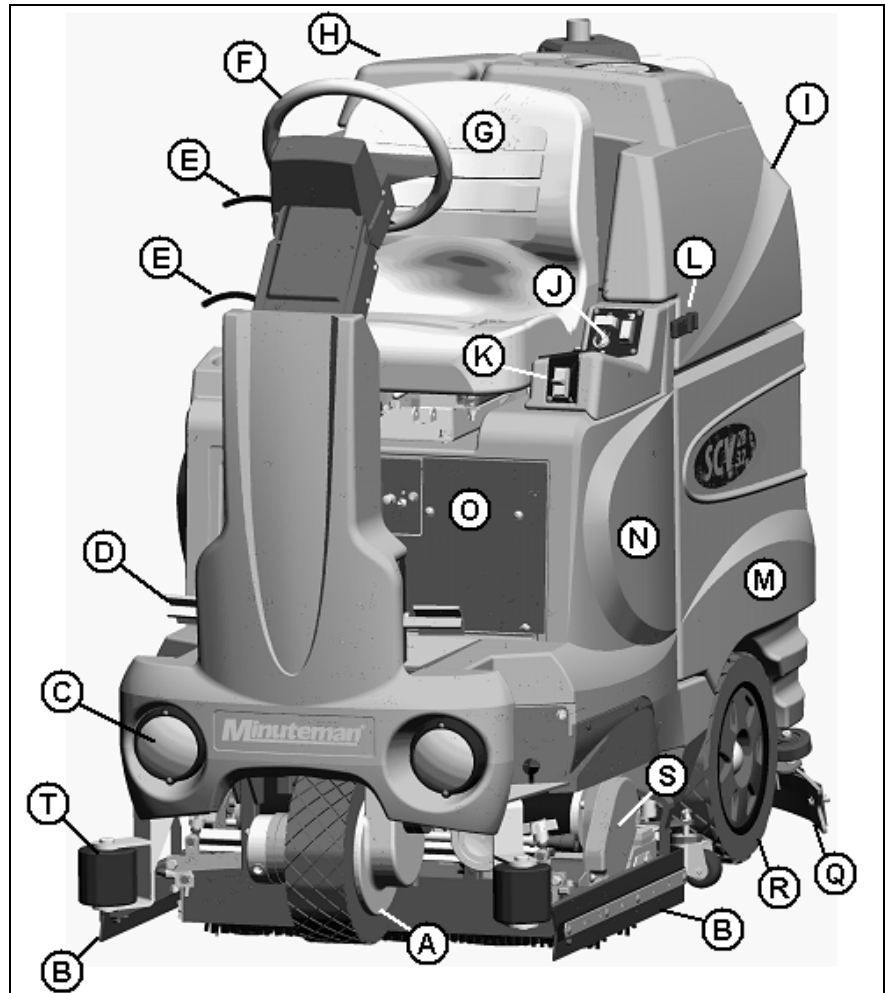

**MACHINE COMPONENTS  
REAR**

<b>A</b>	Rear squeegee
<b>B</b>	Rear wheel
<b>C</b>	Side squeegee
<b>D</b>	Accelerator pedal
<b>E</b>	Solution tank
<b>F</b>	Steering column pivot
<b>G</b>	Tilt-wheel lever
<b>H</b>	LCD display panel
<b>I</b>	Steering wheel
<b>J</b>	Recovery tank lid
<b>K</b>	Vacuum filter access
<b>L</b>	Vacuum diverter
<b>M</b>	Off-aisle wand
<b>N</b>	Recovery tank
<b>O</b>	Battery compartment
<b>P</b>	Clean-out cap
<b>Q</b>	Recovery dump hose
<b>R</b>	Safety latch
<b>S</b>	Recovery hose
<b>T</b>	Scrub deck

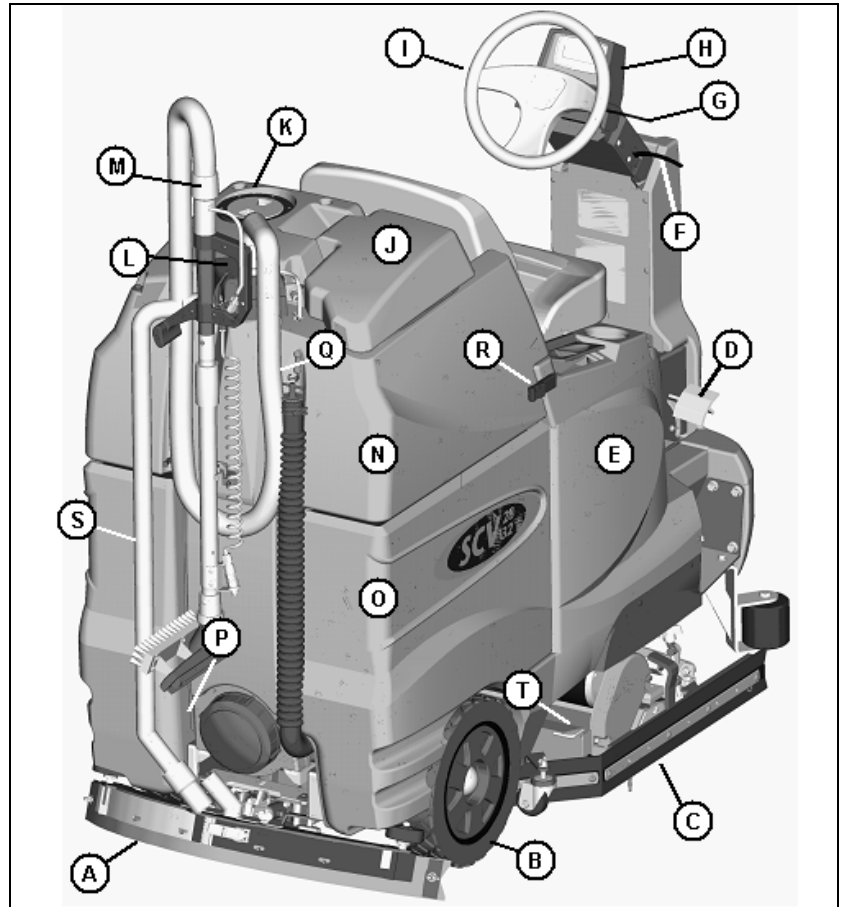

**MACHINE COMPONENTS  
DRIVER'S COMPARTMENT**

<b>A</b>	Operator's seat
<b>B</b>	Solution tank lid
<b>C</b>	Cup holder
<b>D</b>	Solution tank
<b>E</b>	Tilt-wheel lever
<b>F</b>	Accelerator pedal
<b>G</b>	Parking brake
<b>H</b>	LCD display panel
<b>I</b>	Steering wheel
<b>J</b>	Directional switch
<b>K</b>	Control console
<b>L</b>	Safety latch

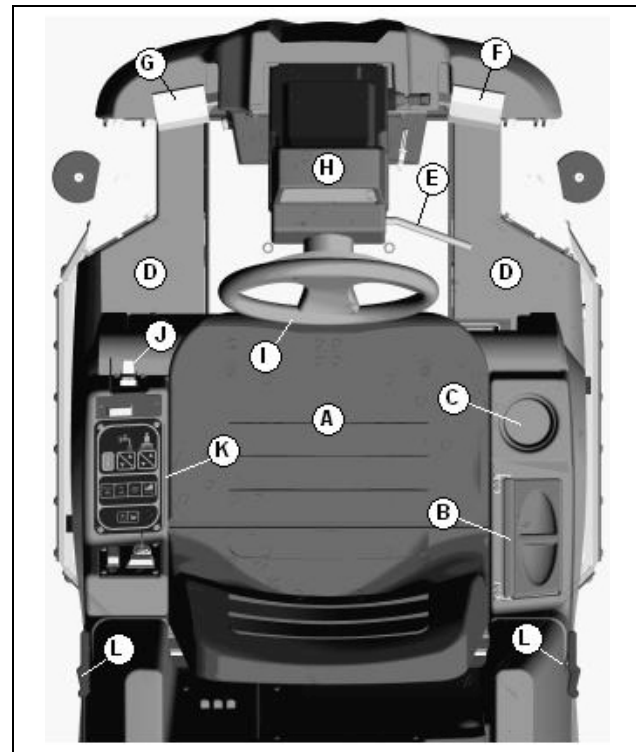



## CONTROL CONSOLE

For operator ergonomics, the control console houses all the primary function buttons are grouped in a central area. The key switch, headlight switch, and off-aisle wand switch are clustered in the back area. The directional switch (forward and reverse) is located in front of the console for easy fingertip operation. The horn button, function buttons, and indicators are located in the main central part of the console.

### Key switch

(A) Controls the machine's power (On/Off) with a key for safety. All operational settings are retained even when the power is turned off and on. This also serves as a reset switch when error or fault codes appear on the LCD screen.

### Off-aisle wand switch

(B) On/Off control for the water supply to the wand and vacuum motor.

### Headlight switch

(C) On/Off control for the headlights.

### Main Keyboard

(D) The main keyboard is divided into three sections: Machine settings, Machine modes, and tank fluid level status. See detail descriptions of each button on the section.

### Horn button

(E) Depressing the button will activate the horn.

### Directional switch

(F) When you flip the switch down, the machine moves forward or flip the switch upward, the machine will go into reverse and activate the back-up alarm.

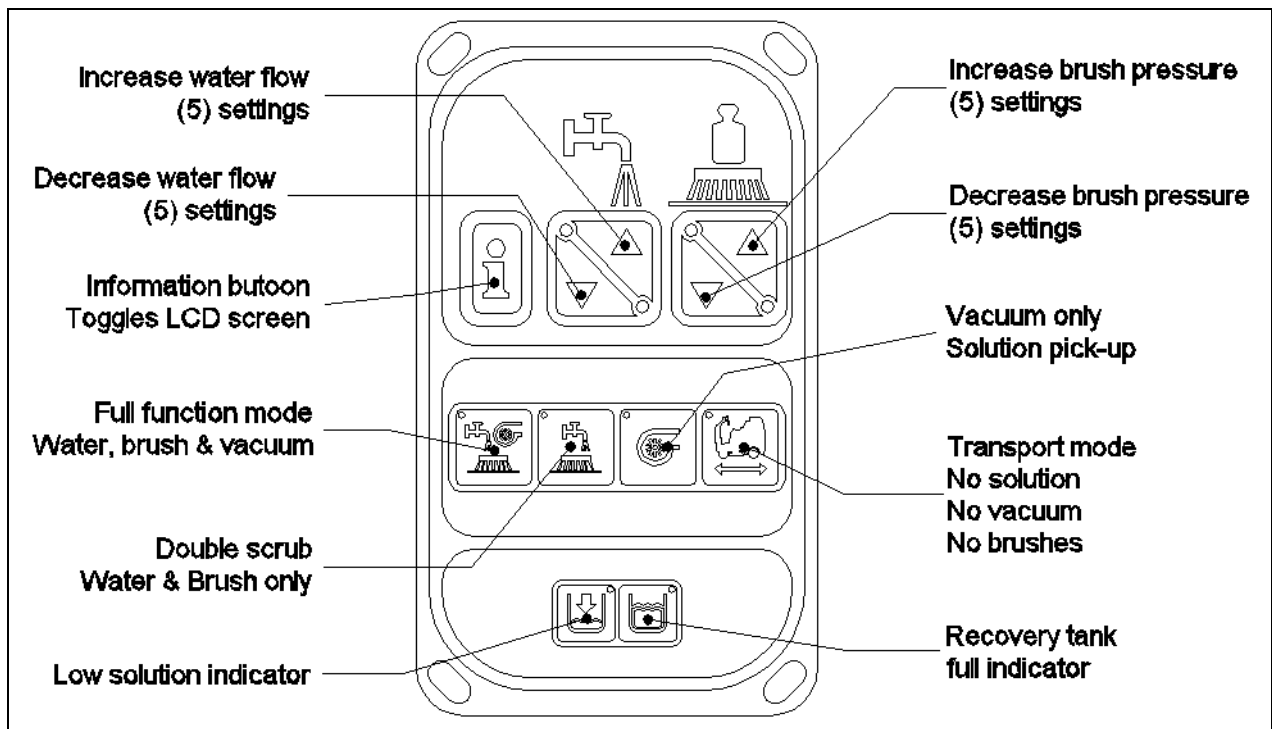
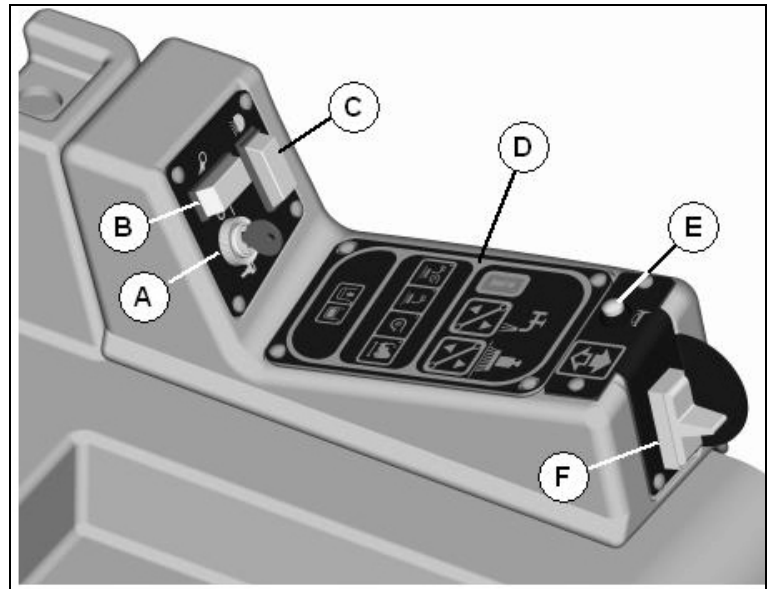

## **MAIN KEYBOARD**

### **FULL FUNCTION MODE**

When this mode is chosen, a green indicator light will illuminate within the full function icon. When the machine is running in this mode, all machine functions will be on. When the operator sets the *directional switch* to the *forward* position and steps the *accelerator pedal*, the solution pump will turn on, the brushes will turn on and be lowered to the floor, and the rear and side squeegees will be lowered to the floor as the vacuum motor turns on. While operating in this mode the solution will be dispersed into the brushes, which will scrub the floor allowing the chemical in the solution to break down the dirt on the floor. As the machine continues to move forward, the vacuum motor will pull the dirty solution water from the rear squeegee into the recovery tank. If the operator stops moving forward and switches the directional switch into reverse, the rear squeegee will rise up (protecting it from damage) and the vacuum motor will turn off after a few seconds. If the operator stops moving in either direction, the machine will automatically raise and turn off the brushes, shut-off the water and raise the rear and side squeegees. Some of the functions will take a little while longer to turn off than others. *See the LCD display section in this book to see the image on the screen looks like when this button is selected.*

### **DOUBLE SCRUB MODE**

When this mode is chosen, a green indicator light will illuminate within the double scrub icon. When the machine is running in this mode, the machine will perform all operations except dirty solution recovery. This mode can be used if the floor is heavily soiled and the chemical will need additional time to emulsify grease and oils that are on the floor. When the operator sets the *directional switch* to either the *forward* or *reverse* position and steps the *accelerator pedal*, the solution pump will turn on, the brushes will turn on and be lowered to the floor. While operating in this mode, the solution will be dispersed into the brushes, which will scrub the floor allowing the chemical in the solution to break down the dirt on the floor. As the machine continues to move forward or back, the rear squeegee and vacuum system are not on, which allows the solution to stay on the floor emulsifying the grease and oil. If the operator stops moving in either direction, the machine will automatically raise and turn off the brushes. After double scrubbing, the operator should use *the vacuum only mode* to recover the dirty solution water from the floor. *See the LCD display section in this book to see the image on the screen looks like when this button is selected.*

### **VACUUM ONLY MODE**

When this mode is chosen, a green indicator light will illuminate within the vacuum only icon. When the machine is running in this mode, the machine will only lower the rear squeegee and turn on the vacuum system to recover the dirty solution from the floor. This mode is usually chosen after double scrubbing to recover the dirty solution but it can also be used to pick up spills. When the operator sets the *directional switch* to *forward*, the rear squeegee will be lowered to the floor as the vacuum turns on, pulling the dirty solution water from the rear squeegee into the recovery tank. If the operator stops moving forward and sets the directional switch to *reverse*, the rear squeegee will retract (protecting it from damage) and the vacuum motor will turn off after a few seconds. If the operator quits moving in either direction, the machine will automatically raise the squeegee and turn off the vacuum motor after a few seconds. *See the LCD display section in this book to see the image on the screen looks like when this button is selected.*

### **TRANSPORT MODE**

When this mode is chosen, a green indicator light will illuminate within the transport icon. When the machine is set in this mode, none of the cleaning functions of the machine will operate. This mode is only used to transport the machine from one location to another at a faster rate of speed. *See the LCD display section in this book to see the image on the screen looks like when this button is selected.*

### **INFORMATION BUTTON**

Depressing the “i” button will generate specific information such as the machine hour meter, brush motor hours, and traction motor hours on the LCD display for a few seconds. Keeping this button depressed will display these items of information for an indefinite amount of time until you release the button. This button toggles the information on the screen being displayed from machine settings and hour meter information. *See the LCD display section in this book to see the image on the screen looks like when this button is selected.*

**WATER FLOW ADJUSTMENT**

These buttons are used to adjust the flow of solution to the brushes. The buttons can be used to select no flow or one of five solution flow rates where: **1 bar = .25 gpm, 2 bars = .44 gpm, 3 bars = .63 gpm, 4 bars = .82 gpm, and 5 bars = 1 gpm.** Either pressing the increase or decrease flow rate buttons adjusts the volume of solution flow to the brushes and is displayed on the LCD screen and represents the flow rate setting selected. The flow adjustments can be made in either the *Full function* or *Double scrub* mode. See the *LCD display section in this book to see the image on the screen looks like when this button is selected.*

**BRUSH PRESSURE ADJUSTMENT**

These buttons adjust the brush pressure. The buttons can be used to select one of five brush pressure settings: **1 bar = lightest, 2 bars = light, 3 bars = medium, 4 bars = heavy, and 5 bars = heaviest.** The pressure is adjusted either by pressing the increase or decrease brush pressure buttons. The number of bars displayed on the LCD screen represents the brush pressure setting selected. The brush pressure adjustments can be made in either the *Full function* or *Double scrub* mode. See the *LCD display section in this book to see the image on the screen looks like when this button is selected.*

**EMPTY SOLUTION TANK INDICATOR**

The light inside this icon will be illuminated when the solution tank is empty. At the same instant, the LCD display will have a flashing bar on the solution flow icon signaling the operator of the solution tank status and the solution pump shuts off. See the *LCD display section in this book to see the image on the screen looks like when this button is selected.*

**RECOVERY TANK FULL INDICATOR**

The light inside this icon will be illuminated when the recovery tank is full. At the same instant, the LCD display will have a flashing bar on the vacuum system icon signaling the operator of the recovery tank status. After this warning, the rear squeegee will automatically raise and the vacuum motor will shut off automatically after a few seconds. See the *LCD display section in this book to see the image on the screen looks like when this button is selected.*

**LCD DISPLAYS**

The following images below are displayed when selecting the controls or buttons discussed above. The battery gauge bar will always be displayed whenever the machine is turned on.

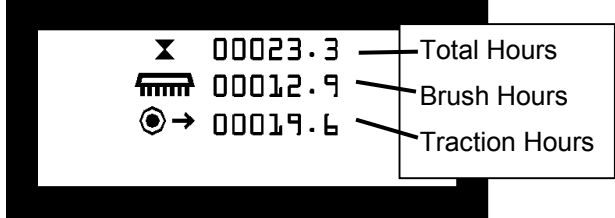
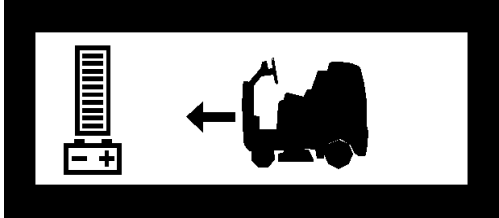
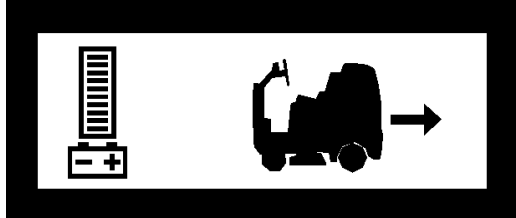
<p><b>KEY SWITCH</b> When switch is turned on, the Minuteman logo will appear in the middle of the screen.</p> 	<p><b>INFORMATION BUTTON</b> Pressing the "i" button will display hours logged on specific components</p> 
<p><b>DIRECTIONAL SWITCH FORWARD</b> Silhouette of the machine with arrow pointing forward.</p> 	<p><b>DIRECTIONAL SWITCH REVERSE</b> Silhouette of the machine with arrow pointing backward</p> 

**FULL FUNCTION MODE**

The vacuum icon with moving arrows, the brush pressure bars and water flow bars will be displayed.

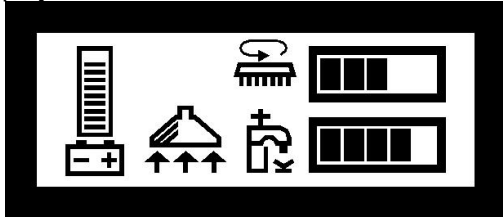

**DOUBLE SCRUB MODE**

The brush pressure bars and water flow bars will be displayed.

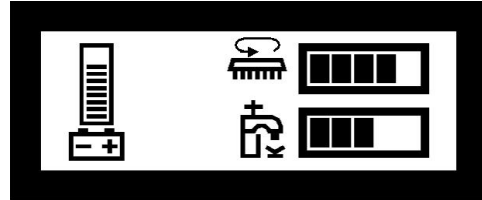

**VACUUM ONLY MODE**

The vacuum symbol will be displayed and no bars displayed for brush and flow icons.

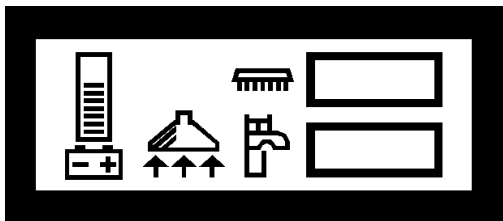

**TRANSPORT MODE**

Silhouette of the machine will be displayed and arrow pointing to a direction as selected on the directional switch.

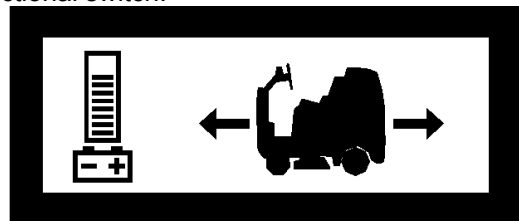

**BRUSH PRESSURE ADJUSTMENT**

Increasing pressure adds more bars to the scale; decreasing pressure removes bars from the scale.

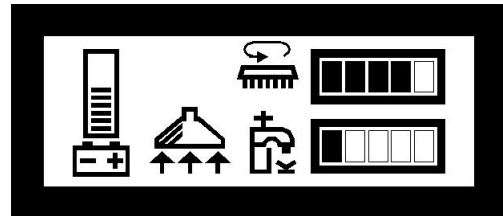

**WATER FLOW ADJUSTMENT**

Increasing flow adds more bars to scale; decreasing flow removes bars from scale.

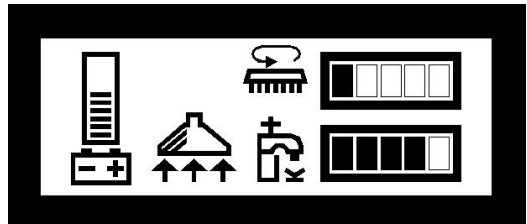

**EMPTY SOLUTION TANK INDICATOR**

A flashing bar across the water flow icon will be displayed.

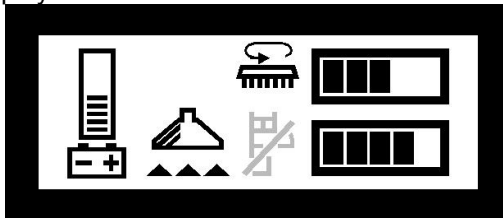

**RECOVERY TANK FULL INDICATOR**

A flashing bar across the vacuum icon will be displayed.

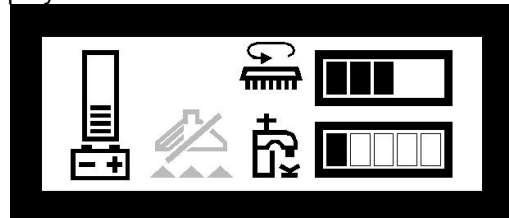

**LOW BATTERY INDICATOR**

The battery gauge bar icon will be flashing to signal the operator that the machine is almost out of power. Once this signal is displayed to the operator, all functions will shut off including the transport mode. The operator has to turn the *key switch OFF and then, ON* to reset the machine. The machine then will only have a few minutes left of reserve power for a short *Vacuum only mode* to pick up remaining solution on the floor and *Transport power*.

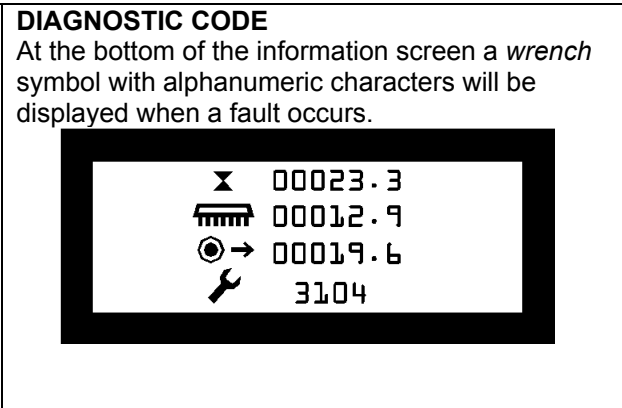
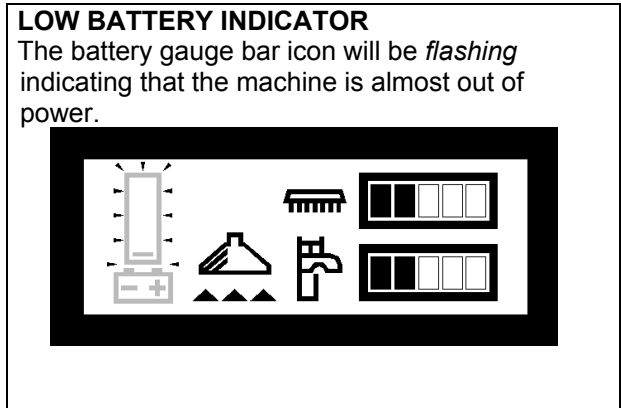

**FAULT / DIAGNOSTIC CODE**

At the bottom of the information screen a *wrench* symbol with alphanumeric characters will be displayed when a fault occurs. In most cases, resetting the machine will correct this condition. The operator has to turn the *key switch OFF and then, ON* to reset the machine. If this does not work servicing the machine may be necessary. Below is a list of fault and diagnostic codes for troubleshooting. See *Troubleshooting tips section for further details*.

SCV Fault Codes	
<b>Switch Reference Codes</b> <i>May indicate incorrectly wired input switches.</i>	<b>07xx</b>
<b>Throttle Codes</b> <i>May indicate incorrectly wired or faulty potentiometer.</i>	<b>081x</b>
<b>Power Down Error</b>	<b>0A01</b>
<b>Supply Over Current</b>	<b>1310</b>
<b>Solenoid Brake Codes</b> <i>May indicate open or short circuit solenoid brake.</i>	<b>150x</b>
<b>High Battery Voltage</b>	<b>1600</b>
<b>Throttle Specification Modified</b>	<b>1D02</b>
<b>Inhibit Activated</b>	<b>1E03</b>
<b>Low Battery Voltage</b>	<b>2C0x</b>
<b>Battery Lock Out</b>	<b>2C02</b>
<b>Throttle Displaced Code</b> <i>May indicate incorrectly wired or faulty potentiometer.</i>	<b>201</b>
<b>Bridge Supply Faults</b> <i>May indicate problem with connection of motors.</i>	<b>310x</b>
<b>Freewheel Errors</b> <i>Check condition of freewheel switch and connections.</i>	<b>700x</b>
<b>LCD Module Communications Codes</b> <i>Serial connections to LCD Module may be intermittent.</i>	<b>750x</b>
<b>Brush Motor Code</b>	<b>760x</b>
<b>Vacuum Motor Code</b>	<b>770x</b>
<b>Traction Motor Code</b>	<b>780x</b>
<b>Emergency Stop or Belly Button Code</b>	<b>790x</b>

## OPERATION OF CONTROLS

### POWER SAVE MODE

The SCV is equipped with a power save feature to conserve battery power. If the key switch power is left ON and none of the controls are activated for a period of fifteen minutes, the SCV automatically goes into "power down mode" and turns OFF the power to conserve your batteries in case the operator forgets to turn the key switch off or leaves the machine unattended.

### ACCELERATOR PEDAL

Located on the right side of the operator compartment on the floor is the accelerator pedal. This pedal controls the propelling speed of the machine. The farther the pedal is pushed down the faster the machine will travel. As discussed earlier, the directional switch governs the direction of travel the machine will take. Switching the directional switch with your foot pushed on the pedal will make your machine change directions (a very slight delay may occur before the direction of travel changes when switching directions on the fly). The accelerator pedal is interlocked with the seat switch, making machine propulsion not possible without the operator sitting on the seat.

### SEAT

The ergonomically designed seat is located on top of the solution tank. There is a lever under the seat that allows the operator to adjust the seat forward or backward for operator comfort. There is an interlock switch located inside the seat. This makes it impossible to engage the traction drive circuitry without the operator on the seat. If the operator were to fall off the machine, the traction drive circuitry would turn off.

### STEERING WHEEL

The steering wheel (FIGURE 1) is adjustable for operator comfort by pulling the *tilt-wheel lever* back and positioning the steering wheel up or down (there are four possible positions). Also, a two-position steering column (FIGURE 2) feature gives the operator easier access to the driver's compartment when climbing into and dismounting from the machine. By pulling on the *steering column pivot pin* and positioning the steering column in an upright fashion, enables the operator more room when climbing up and down the machine. The operator can then position the steering column in its normal driving position by returning the steering column back in its normal position.

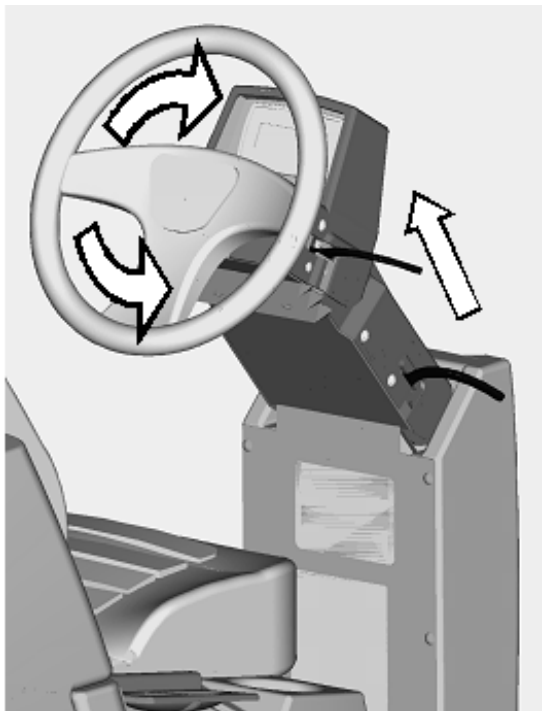

FIGURE 1

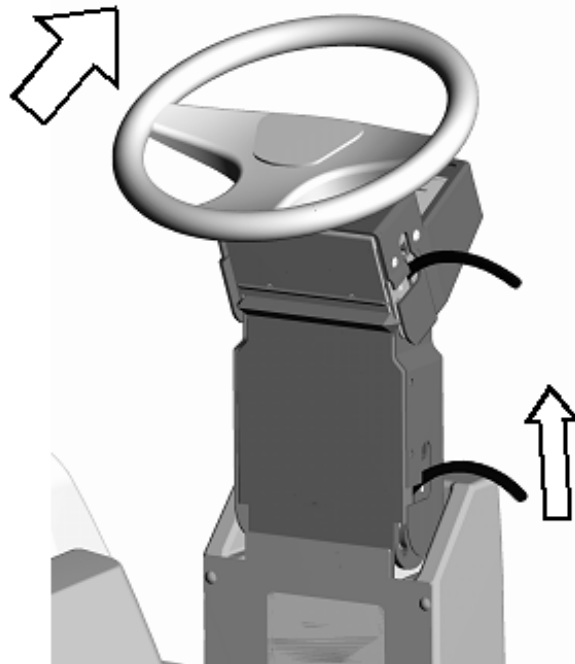
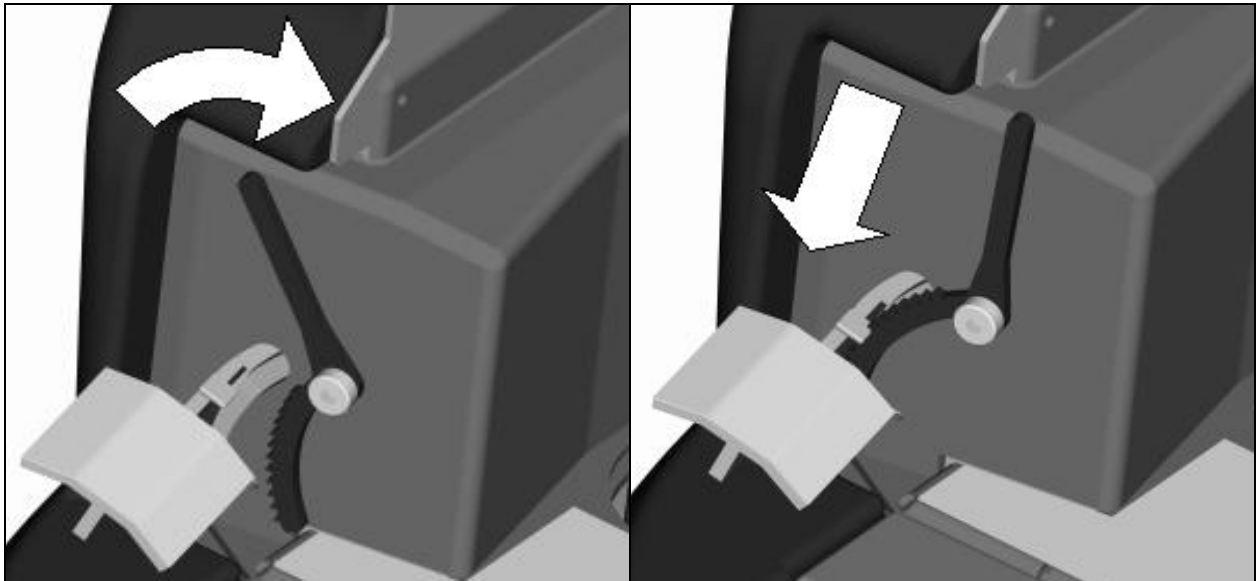

FIGURE 2

## MECHANICAL & PARKING BRAKE

Located on the left side of the operator compartment on the floor is the mechanical brake which doubles as the parking brake. Even though the machine is equipped with a regenerative braking system, the mechanical brakes can be activated by pushing down on the pedal and apply brakes on the rear wheels. The mechanical brake also doubles as a *Parking brake*. To set the parking brake, press down on the brake pedal as far down as possible; then, engage the *parking brake lever* teeth with the brake pedal tab by rotating the lever clockwise. This will keep the brakes on the rear wheels. To disengage the parking brake, simply push down on the brake pedal until the parking brake lever disengages itself from the pedal tab. Another safety feature on the machine is the *Electro-magnetic brake* built-in on the traction drive motor.

When the machine's power is turned off (using either the key or the emergency button), the *E-mag* brake is activated and the traction motor is prevented from moving. ***The mechanical /parking brake system is self-cleaning and periodic use is recommended to avoid build up of foreign matter that may cause seizing in the mechanism and rust build up.***



## EMERGENCY DISCONNECT BUTTON

This button is located in the middle of the electrical panel that is directly underneath the operator's seat. When the *red* emergency button is pressed, power will be turned off. Use this button in case of a machine emergency. The red knob needs to be raised in order to run the machine. To reactivate, turn the knob as shown by the arrow on the switch and the button will pop up. *All operational settings are retained even when the power is turned off and on.*

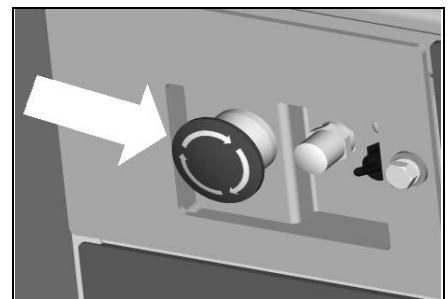

## CIRCUIT BREAKERS

The circuit breakers are located next to the emergency disconnect button. The **6-amp breaker** (indicated by white arrow). This breaker protects all auxiliary circuits on the machine (headlights, horn, and back-up alarm). The **100-amp breaker** (indicated by black arrow) protects the main system circuit (controller). Each main component is individually protected with an internal breaker built-in the controller. (See fault code table) and can be reset by turning the key switch off a few seconds and then on again.

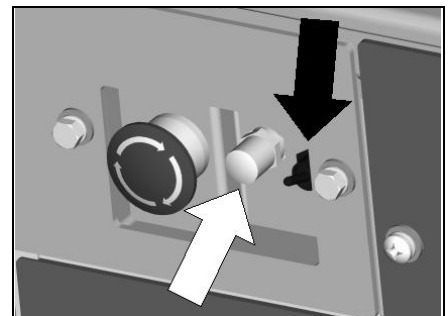

### BATTERY COMPARTMENT

The battery compartment is located on the rear of the machine under the recovery tank. Unlatching the two safety latches on the side of the machine enables the operator to tilt the recovery tank and access the batteries for servicing and maintenance (make sure recovery tank has been drained before tilting). The battery compartment contains six 6-volt batteries connected in series. Connect the batteries according to the battery connection diagram (see *diagram*). The recommended batteries are 370Ah (Minuteman P/N 956715).

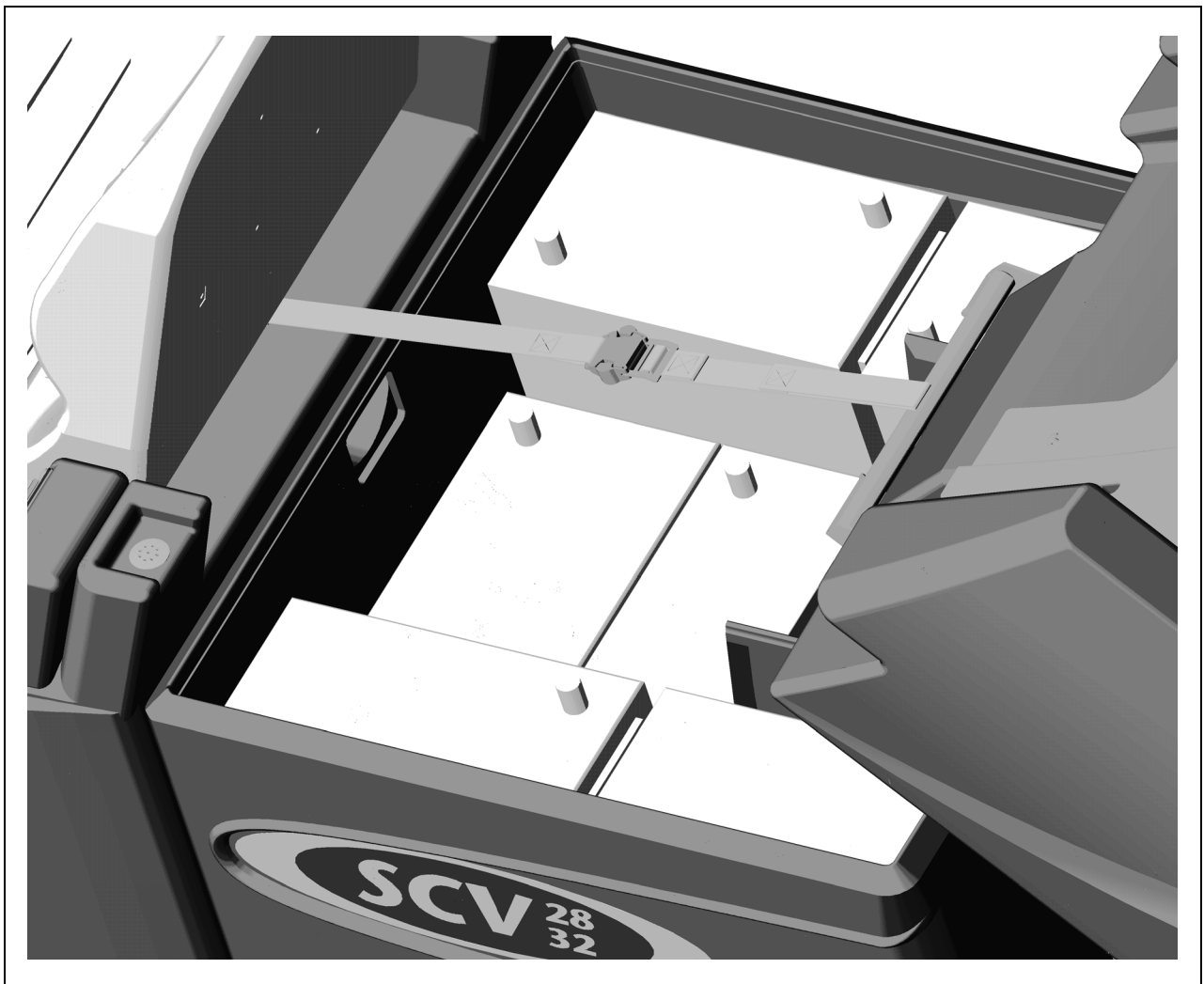
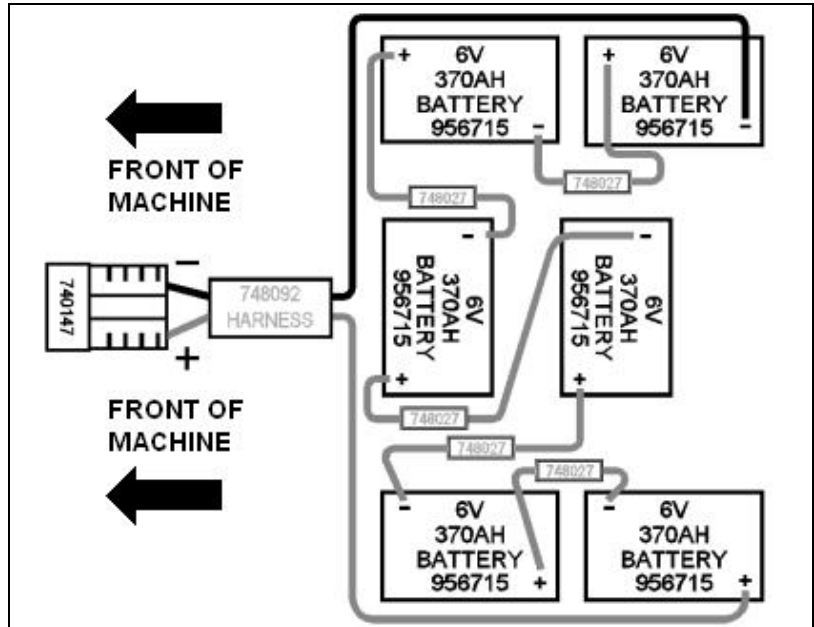



## SCRUB DECK

Minuteman offers two deck types (*Cylindrical and Disc*) to fit your specific needs. The SCV design is very dynamic wherein the decks are interchangeable in a matter of minutes whenever necessary (removal of four bolts, and two quick-connects). The *cylindrical brush deck* has five built-in spray jets to uniformly dispense cleaning solution on the floor and a wet sweeping debris tray to collect loose objects on the floor. The *disc brush deck* dispenses cleaning solution through the center hub and contained within the bristle area for efficient agitation of cleaning solution to the floor and channeled to the rear of the machine. The disc brushes are also easily removed and installed with the quick release clamp by using any of the three access doors. Another nice feature that these scrub decks have is the ability to have uniform brush pressure applied to the floor at all times. Since the scrub deck brush pressure is computer controlled, it will automatically adjust and compensate to uneven contours on the floor while maintaining brush pressure.

### CYLINDRICAL SCRUB DECK

A	Housing
B	Spray jets (5)
C	Access door (2)
D	Nut, Access door
E	Debris box
F	Connector, water
G	Mounting bracket
H	Connector, power
I	Brush motor (2)
J	Pulley cover (2)
K	Bolt (4)
L	Lock washer (4)
M	Flat washer (4)

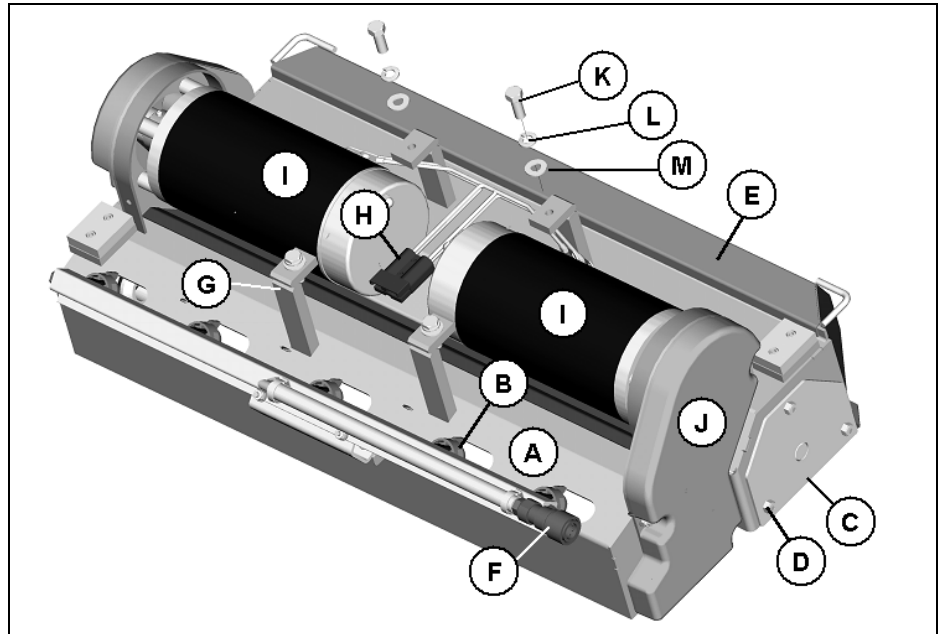

### DISC SCRUB DECK

A	Housing
B	Access door (6)
C	Brush skirt
D	Brush motor
E	Mounting bracket
F	Flat washer (4)
G	Lock washer (4)
H	Bolt (4)
I	Connector, power
J	Connector, water

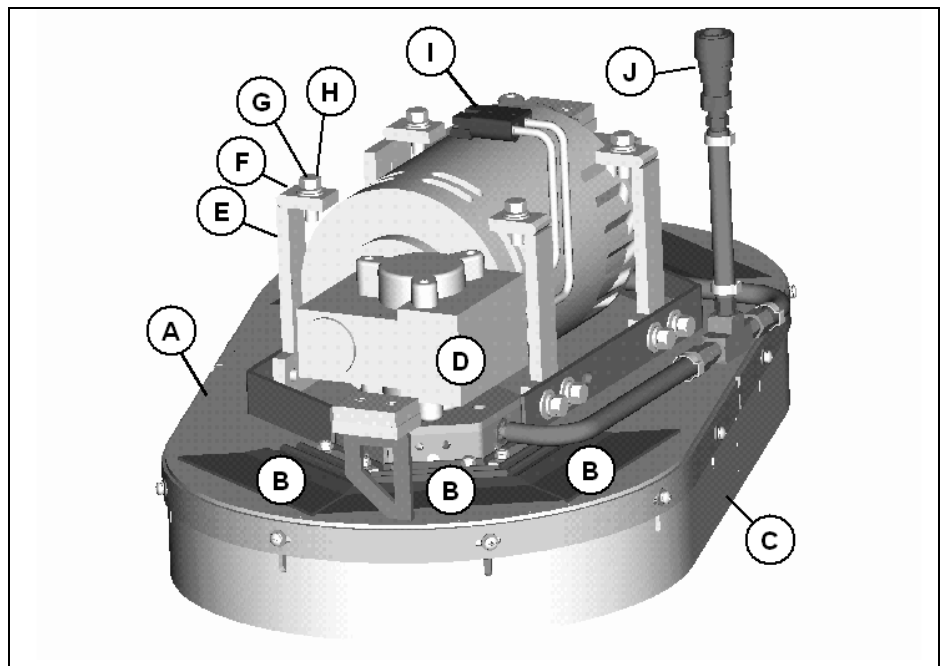

## SCRUB DECK INSTALLATION

When installing a cylindrical deck to a machine:

1. Install brushes **after** the deck has been mounted to avoid flat spots on the brushes.
2. Use a piece of cardboard underneath the deck to prevent scratches to the painted surface when sliding the deck under the machine.
3. Make sure the scrub deck is oriented correctly with the spray jets towards the front of the machine.

When installing a disc scrub deck to a machine:

4. Install brushes on the scrub deck; this aids the installer in sliding the deck assembly into position.
5. Make sure the scrub deck is oriented correctly with the solution hose tee fitting towards the front of the machine.

## INSTALLATION INSTRUCTIONS

1. Park the machine on a flat or level surface.
2. Activate the parking brake.
3. Remove the 2 screws that fasten each plastic side covers on the machine.
4. Turn the key switch to the ON position and select the transport mode on keyboard.
5. Slide the scrub deck assembly underneath the machine (follow instructions as described above)
6. Position the scrub deck to align the mounting brackets with the mounting lugs on the lift linkage.
7. Lower the lift linkage to the floor by pressing the increase brush pressure button for ten seconds.  
**(Pressing the up and down brush pressure button for ten seconds toggles the scrub deck control into a manual up and down mode for the scrub deck linkage).**
8. Lower the lift linkage mounting lugs until they barely touch the scrub deck mounting brackets.
9. Fasten with the four (4) 711242 bolts, 711515 flat washer and 711546 lock washer.
10. For cylindrical scrub deck only:
  - a. Remove the two access doors (one each end) by removing the (3) nyloc nuts.
  - b. Install the brushes by sliding through the access opening.
  - c. Align the notches on the brush with the drive pins on the hub.
  - d. Push brush all the way until it bottoms out.
  - e. Insert access door hub to the other end of brush.
  - f. Reinstall nuts and tighten.

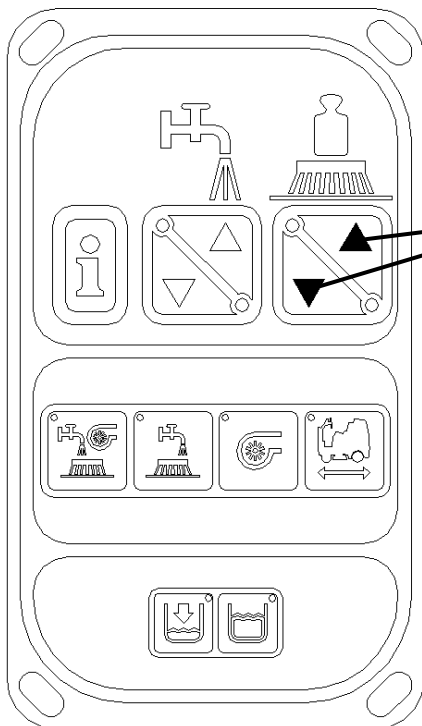

Depressing one of these buttons for ten seconds will switch you into the manual raise/lower mode. When you are in this mode, these buttons control the movement of the lift linkage mechanism. To get out of this mode, simply reset the machine by turning the key switch off.

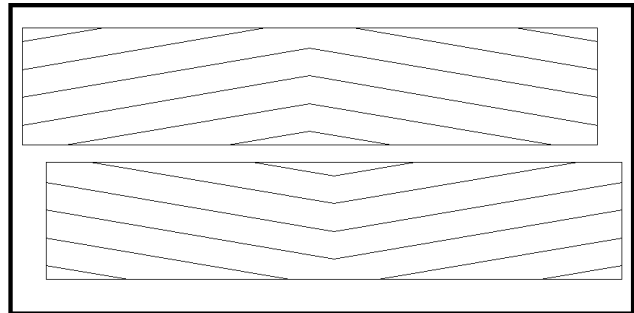

Cylindrical scrub brushes must be installed with the chevron pattern pointing away from each other for best water and debris pick up.

## SIDE SQUEEGEE

The side squeegees (left and right) are attached to the machine mainframe. These items channel the dirty solution to the rear squeegee, helping contain the water within the machine's cleaning path. These squeegees are raised when the scrub deck is in the raised position. When the scrub deck is deployed, the side squeegees are also lowered. A lift bracket (item H) raises the side squeegee off the floor when the machine is in a non-scrubbing mode. The side squeegees are equipped with an adjustable caster (item D) to control the blade deflection (lowering the caster lessens blade deflection). To adjust the deflection, loosen the wing jam nut (item C) and turn the caster stem as described below. If the squeegee blade is deflecting too much, the casters need to be lowered to control the down pressure. Lower the caster by turning the exposed threaded stem on the caster clockwise. Make the adjustment a few turns at a time. If the blades are not deflecting enough, raise the caster by turning the stem counter-clockwise to adjust the caster height to allow more down pressure on the squeegee. A turnbuckle adjustment knob (item F) is provided to adjust the pitch for optimum wiping performance. To adjust, loosen the two knurled lock nuts (item E) and turn the turnbuckle to make the necessary adjustments. After the necessary adjustments are made, retighten the knurled nuts to secure the adjustment. To clean out the debris box (item I), slightly lift the debris box up by its handles and slide out towards you. To remove the side squeegees, pull out the cotter pin (item G) from both mounting pins and slide the assembly towards the back of the machine.

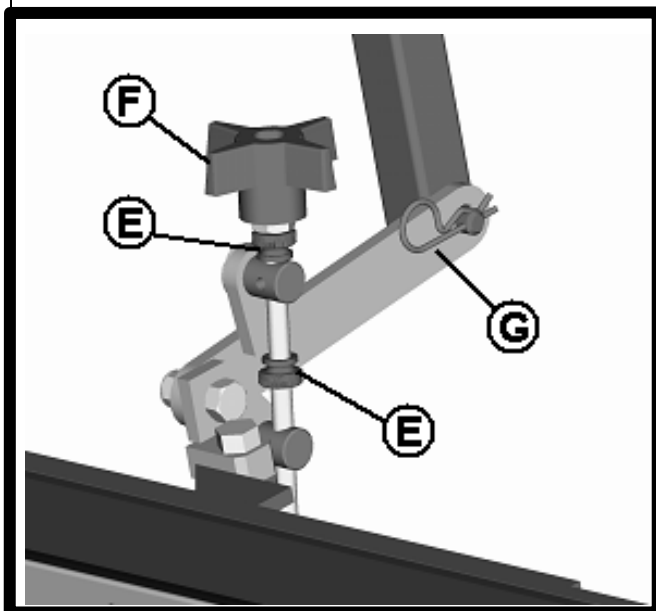
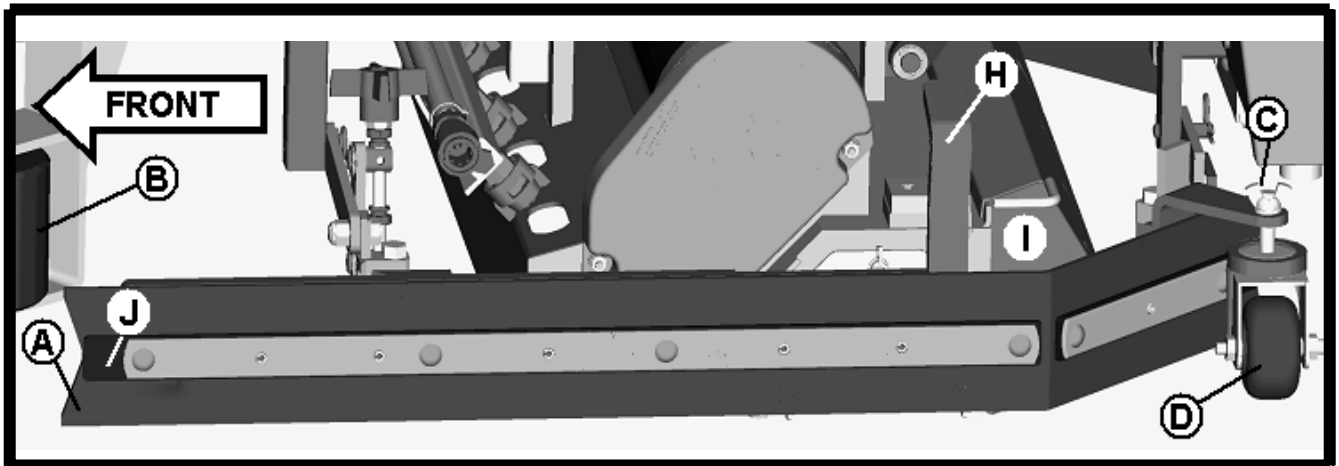

### SIDE SQUEEGEE COMPONENTS

- A. Squeegee blade
- B. Roller bumper
- C. Wing jam nut
- D. Swivel caster
- E. Knurled lock nut (2)
- F. Turnbuckle knob
- G. Cotter pin
- H. Lift bracket
- I. Debris box
- J. Backer strip

## REAR SQUEEGEE

The rear squeegee is the main element that acts as the conduit that transfers the spent solution into the recovery tank. A daily maintenance check of this component is essential to have optimum machine performance. The rear squeegee assembly is equipped with a universal front blade that allows the operator the option to use a slotted and a non-slotted side for specific applications. Each blade configuration has two usable edges. The rear blade however has four usable edges.

***The squeegee is pre-adjusted at the factory. Adjustments may be required to get optimum performance for different floors and conditions.***

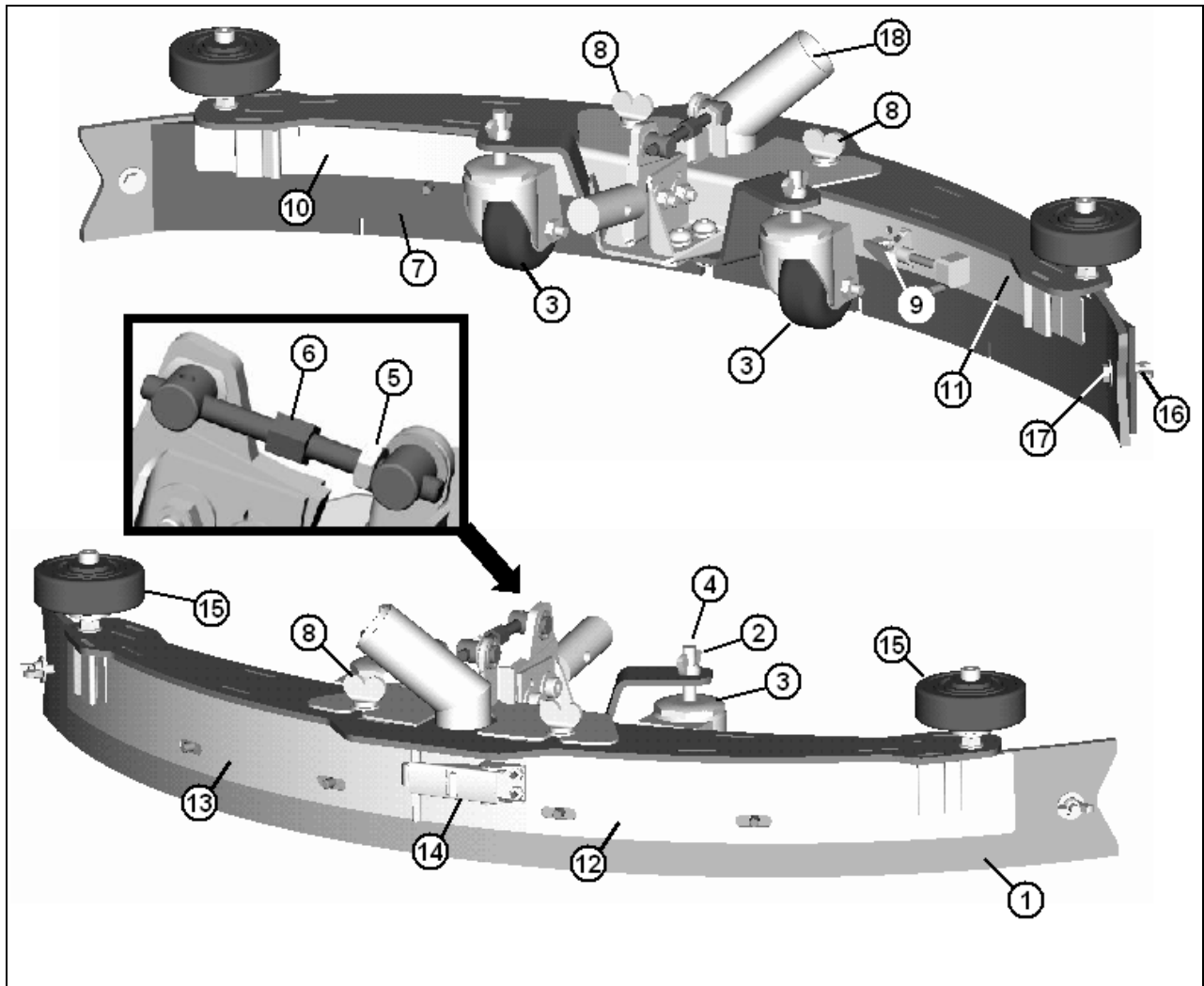

### REAR SQUEEGEE COMPONENTS

- |                         |                             |
|-------------------------|-----------------------------|
| 1. Rear squeegee blade  | 10. Front strap (long)      |
| 2. Wing jam nut (2)     | 11. Front strap (short)     |
| 3. Caster stem          | 12. Rear strap (latch side) |
| 4. Swivel caster (2)    | 13. Rear strap (catch side) |
| 5. Lock nut             | 14. Latch                   |
| 6. Turnbuckle           | 15. Guide wheels (2)        |
| 7. Front squeegee blade | 16. Nylon wing bolt (2)     |
| 8. Wing bolt (2)        | 17. Nylon bolt (2)          |
| 9. Toggle clamp         | 18. Recovery hose intake    |

## REAR SQUEEGEE ADJUSTMENT

1. Ensure that the scrubber is on a relatively flat surface. Turn on the key switch and select the **Vacuum only** mode. This lowers the squeegee to the floor and turns the vacuum motor on.
2. Move the scrubber one or two feet forward slowly while someone behind the machine checks the rear squeegee blade (item 1) for uniform deflection to the floor.
3. If uneven deflection or lay is evident, minor adjustments may be necessary to avoid streaking and uneven wear on the blade.
4. To correct this, loosen the wing jam nut (item 2) in order to adjust the caster height. If the squeegee blade is deflecting too much, the casters (item 3) need to be lowered to control the down pressure. Lower the caster by turning the exposed threaded stem (item 4) on the caster clockwise. Make the adjustment a few turns at a time. **Repeat step 2.**
5. If the blades are not deflecting enough, raise the caster by turning the stem counter-clockwise to adjust the caster height to allow more down pressure on the squeegee. **Repeat step 2.**
6. Make sure there is even deflection on the entire length of the rear blade. Adjust the casters and retighten the wing jam nuts to lock the caster setting in place.
7. Pitch adjustment is necessary if the outer ends on the squeegee blade do not contact the floor and there is too much deflection in the middle area or if the outer ends are over deflected and there is no contact in the middle.
8. To adjust the pitch, repeat step 2.
9. Loosen the lock nut (item 5) in the turnbuckle assembly. Turning the turnbuckle (item 6) clockwise or counter-clockwise controls the forward and backward pitch of the squeegee. Having the rear blades deflected uniformly along its entire length is the desired set-up.
10. Repeat step 2 until desired set-up is achieved.
11. In certain applications where a non-slotted front wiper blade (item 7) is needed, detach the rear squeegee assembly by loosening the two wing bolts (item 8). Unlock the toggle clamp (item 9) on the front squeegee to release the front long strap (10) and slide the front short strap (item 11). Flip the blade over to the non-slotted side. Reattach the straps and lock the clamp back in place.
12. You can also easily replace the rear blade by unlatching the latch (item 14) and removing the two rear straps (items 12 & 13) by sliding them off the assembly. You can then flip the blade over in order to use a new edge for better wiping action.

## OFF-AISLE WAND

The SCV is equipped with a ready-to-use built-in telescoping off-aisle wand (item A) system for use in hard to reach areas. This integrated system eliminates attaching hose for use and detaching hoses for storage. By turning the *pump switch* ON (located on the control console) and flipping a lever that doubles as the wand hanger, the off-aisle wand is ready to use in seconds. Flipping the lever up (item D) diverts the vacuum flow from the main rear squeegee intake (item E) to the off-aisle wand intake (item F). After use, simply flip the lever back down to its normal position to use as the hand hanger. The wand is also equipped with the patented flip-flop tool that allows the operator to switch from scrub brush to squeegee tool by just rotating the tool end.

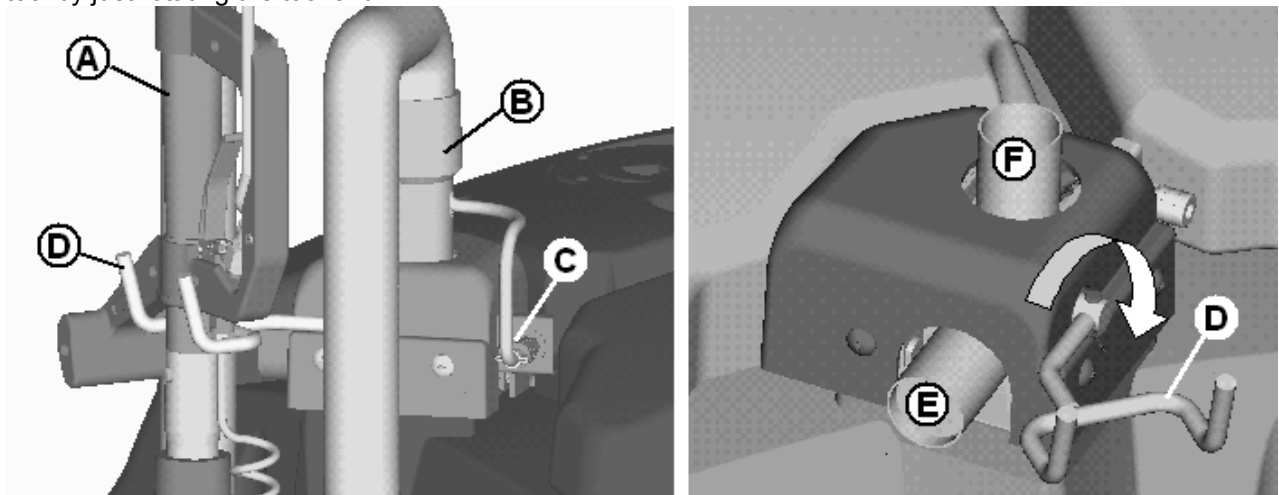

## OFF-AISLE WAND TOOL

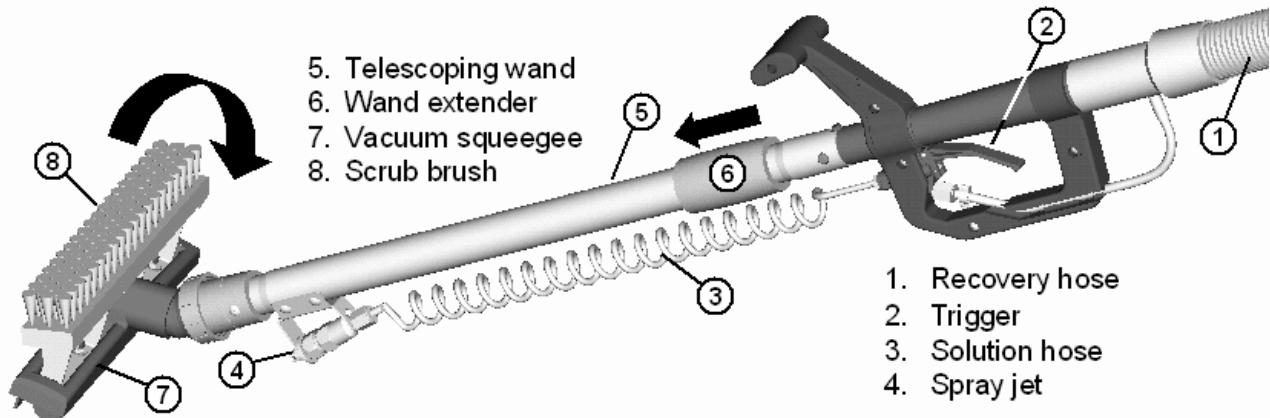

The off-aisle wand tool as described in the previous page is composed of the following items:

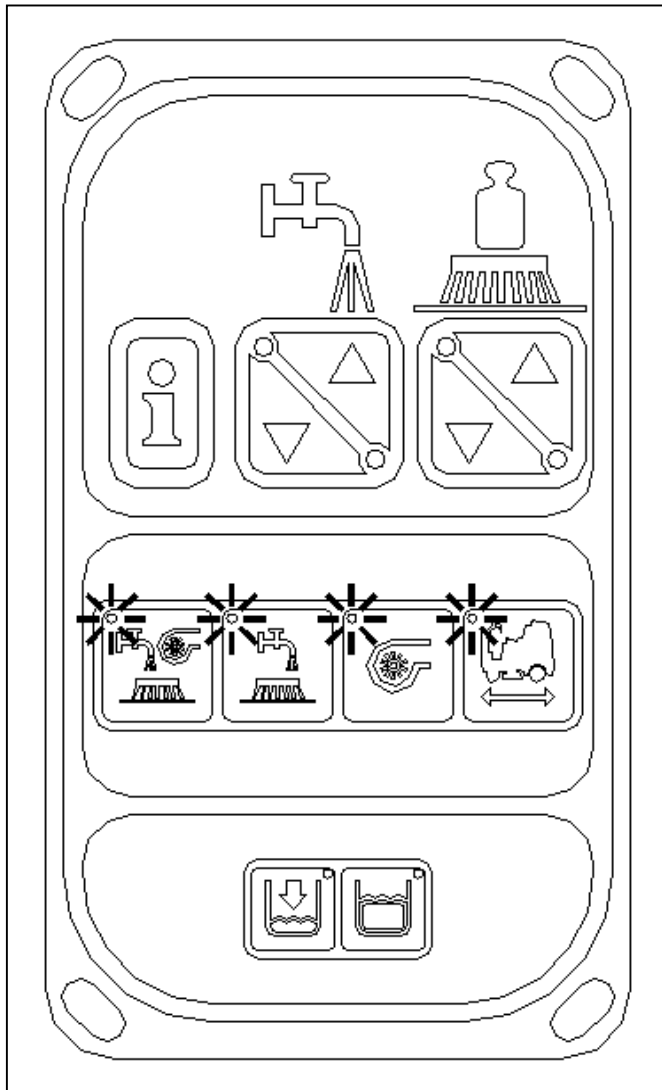

1. The **recovery hose** is connected to the end of the wand on one end and to the diverter assembly (item F) on the other end. This hose has swivel cuffs on both ends that allow the operator a good range of motion and the solution hose to be inside the recovery hose.
2. The **trigger** controls the solution flow to the spray jet. Squeezing the trigger opens an internal valve to dispense cleaning solution.
3. The coiled **solution hose** acts as a conduit from the trigger to the spray jet, and allows hose to be extended along with the wand.
4. The **spray jet** dispenses the cleaning solution to soak soiled areas that are not accessible to the main scrub deck.
5. The **telescoping wand** allows the length to be adjusted for operator comfort and better storage when not in use.
6. Sliding the **wand extender** forward (as shown above) extends the wand length during use and retracts the wand by pulling it back for the storage position.
7. The flip-flop tool gives the operator complete flexibility when changing from the **scrub brush** mode to **vacuum squeegee** mode by simply rotating the end.

When the off-aisle wand switch is turned ON, the four (full function, double scrub, vacuum only and transport) mode lights in the keyboard will flash to indicate that you are in the off-aisle tool mode. This switch turns on the pump to supply solution to the wand spray jet and the vacuum motor to recover the dirty water. When the recovery tank is full, the vacuum motor and the solution pump automatically shuts off.

## THE SCV RIDER

This machine was designed with total operator comfort and ease of use in mind. All machine components have been designed as a total system to efficiently clean dirty floors. The SCV has four available scrub head types and sizes to fit specific applications. *Please contact your Minuteman representative for specific recommendations for the correct scrub head type, size, and brush type and chemical applications.*

Before using the machine, always perform the following steps to ensure proper machine operation.

- Check under the machine for leaks.
- Check the rear and side squeegees for wear and damage.
- Check the steering for proper operation.
- Check the solution and recovery tanks.

After using the machine, always perform the following steps:

- Check the battery charge level. Charge batteries if necessary. When charging batteries, extra precaution is required:
  - Battery acid can cause burns. When working on or around batteries, always wear protective clothing and safety glasses. Remove metal jewelry. Do not lay tools or metal objects on top of the batteries.
  - Charging batteries generate explosive gasses. **DO NOT CHARGE BATTERIES WHEN OPEN FLAMES OR SPARKS ARE PRESENT. DO NOT SMOKE.** Make sure the charger is turned off before disconnecting it from the batteries. Charge the batteries in a well-ventilated area. Fluid levels should be checked before and after charging and maintained at the proper levels. If low, add water until the metal plates are covered. If the machine is not used for an extended period of time, batteries should be kept fully charged with a boost charge once a week.
- Check for wire, string, or twine wrapped around the scrub brushes.
- Check the squeegees for wear and damage.
- Check the rear squeegee suction hose and off-aisle wand hose for obstructions.
- Empty and clean the debris box (cylindrical systems only).
- Drain and clean the recovery tank.
- Check under the machine for leaks.
- Check the service records to determine maintenance requirements.

### WARNING!

- **Be sure you understand the machine controls and their functions.**
- **While on ramps or inclines, avoid sudden stops when tanks are filled.**
- **Avoid abrupt sharp turns. Slow down driving speed when going downhill.**
- **Always drive up when cleaning ramps.**

### MACHINE OPERATION

**Follow the instructions in preparing the machine for use as described in this manual.**

1. While seated on the machine, adjust the steering wheel to desired position (for comfort and unobstructed view of the LCD panel) using the tilt wheel lever.
2. Turn the **Key switch ON (I)**. The **LCD panel** will light up and display the Minuteman logo for a few seconds and display the *Battery Condition icon* and the last functional setting when the machine was turned off.
3. Release the **Parking Brake** as described in the *Mechanical & Parking Brake section* of this manual.
4. Select one of the four available **Modes** on the **Control Console** for the required task. Refer to the *Main Keyboard section* of this manual for a complete description of the functions.
5. Adjust the **Solution Flow** and or **Brush pressure** to desired setting.
6. Determine the direction you need to travel by selecting **forward** or **reverse** on the **Directional Switch**. The LCD screen will display an icon as described *LCD Section* in this manual. Vary the pressure exerted on the accelerator pedal to propel the machine at the desired speed. Stepping on the accelerator pedal activates.

7. Stepping on the **Accelerator Pedal** turns on the *Transport, Brushes, Water Flow, Vacuum* and lowers the *Rear Squeegee* accordingly to the Mode selected. If the operator steps on the accelerator pedal before, or turns the key switch "ON" at the same time, the machine will not move as a safety precaution. Simply remove your foot off the pedal and step on the pedal again to drive the machine. Please refer to the *Main Keyboard section* of this manual for a complete description of the functions.
8. When **Reverse** is selected on the Directional Switch, the **Back-up Alarm** will be activated and the **Rear Squeegee** automatically is raised when you step on the accelerator pedal. However, the Scrub brushes will continue to rotate and solution will continue to flow.
9. Start scrubbing by driving the machine forward in a straight line at 3/4 speed and overlap each path by 2 to 3 inches. Adjust your speed; brush pressure and solution flow according to the condition of the floor.

**CAUTION!**

**To avoid any damage to the floor, keep the machine moving when the brushes are turned on.**

10. When scrubbing, check behind the machine occasionally to see that all the dirty water is being picked up. If streaking occurs, your **Water Flow** setting may be *too high*, the **Recovery Tank** may be *full*, the **Squeegee hose** may be *clogged*, or the **Rear Squeegee** may require some *adjustment*.
11. Make the necessary adjustments on the **Rear and Side Squeegees** if streaking occurs both in straight paths and in turns. Please refer to the *Rear Squeegee and Side Squeegee* section of this manual before making any adjustments.
12. In cases where the floors are extremely soiled and dirty, the **Double Scrub** mode may be needed. As described in the *Main Keyboard section* of this manual, this mode allows the operator to be able to scrub an area without recovering the cleaning solution with the rear squeegee in the raised position (no vacuum) to allow the cleaning solution a longer time to loosen dirt. A final pass on the same area is made with the mode switched over to either **Full Function** or **Vacuum Only** mode to recover the dirty water.
13. The recovery tank has two safeguards for overflow protection to guard against water from entering the vacuum system when the recovery tank is full. When the *indicator light* is lit up in the **Keyboard**, the **Vacuum icon** in the *LCD Screen* will be *flashing* (see the *LCD Display* section of this manual). The vacuum will stay ON for 15 seconds and then shut-off automatically. A ball float shut-off system has also been integrated into the Recovery Tank. When the dirty water reaches a certain level, the ball gets suctioned into the vacuum manifold and blocks the airflow thus, preventing the machine from picking up more liquid. When this happens, the operator is then required to stop scrubbing and empty the recovery tank.
14. To stop scrubbing, select the **Transport mode**. This will automatically stop the **Solution Flow**, raise the **Scrub deck**, and raise the **Rear squeegee** (there is a 15 second delay for the vacuum motor).
15. Drive the SCV to a designated dirty water disposal area and empty the Recovery tank. To empty, remove the **Drain hose** from its storage hanger. Unscrew the plug and hold the hose end above the water level in the tank to avoid sudden, uncontrolled flow of dirty water. With the plug completely off, carefully direct the water flow to the desired drain. Reinsert the plug and tighten and return to its storage hanger.
16. The recovery tank should be rinsed out to remove solids in the tank. Open the **Cleanout cap** to remove the **Stopper plug**. Tilt the recovery tank (similar to accessing the batteries) and clean the sludge that has settled in the sump area by either back flushing or by scraping it out. Be sure to tightly secure the **Stopper plug** and cleanout cap before continuing to operate the scrubber.
17. Refill the solution tank and continue scrubbing until the job is done or when the machine runs out of power.
18. The **battery gauge bar icon** will flash to signal the operator that the machine is almost out of power. Once this signal is displayed to the operator, *all functions will shut off* (brush will turn off and the scrub deck will raise up, water flow will cease, the rear squeegee will raise up and the vacuum motor will turn off) including the transport mode. The operator has to turn the **key switch OFF and then, ON to reset** the machine. The machine then will only have a few minutes left of reserve power for a short *Vacuum only mode* to pick up remaining solution on the floor and *Transport* power to drive to the battery recharging station.



**AFTER USE:**

1. When finished scrubbing, select the **Transport mode**, *all functions will shut off* (brush will turn off and the scrub deck will raise up, water flow will cease, the rear squeegee will raise up and the vacuum motor will turn off). Drive the machine to a service area for daily maintenance and review items that may need service.
2. Empty the solution tank, by directly opening the **Garden hose valve** underneath the machine into a drain on the floor or use a garden and attach it to the fitting to remotely drain the solution tank. Rinse the tank with clean water to prevent any build-up of dried up chemicals that could cause clogging in the plumbing.
3. Empty the recovery tank as described on line **15** and **16**.
4. Remove the **brushes** or pad holders and rinse them in warm water and hang to dry.
5. Remove the **rear squeegee**, rinse with warm water and reinstall after cleaning.
6. Remove the **side squeegees**, rinse with warm water and remove the **debris box** (cylindrical system only) and clean thoroughly. The debris box can be removed from either side of the machine by tilting the box up and away from the housing and then pulling it out. Reinstall the debris box and side squeegees after cleaning.
7. Check the **maintenance schedule** on the next page and perform any required maintenance before storing the machine.
8. Store the machine indoors in a clean dry place. Keep from freezing. Leave solution and recovery tank lids open for ventilation to prevent odor build-up.
9. Turn **Key switch OFF (O)** and remove key.

## MAINTENANCE SCHEDULE

Daily	Weekly	Monthly	Yearly
Charge Batteries	Check Each Battery Cell(s) Water Level	Lubrication – Grease Fittings, chains, etc.	Check Carbon Brushes
Check/Clean Tanks & Hoses	Inspect Scrub Housing Skirts		
Check/Clean/Rotate the Brushes/Pads	Inspect and Clean Solution Filter		
Check/Clean the Squeegee	Check Foot/Parking Brake for Wear & Adjustment		
Check/Clean Vacuum Shut-Off Float	Clean Spray jets on Cylindrical System		
Check/Clean the Vacuum Motor Foam Filter			
Clean Hopper on Cylindrical System			

- Have Minuteman check the vacuum motor carbon motor brushes once a year or after 300 operating hours. The brush motor carbon brushes should be checked every 500 hours or once a year.

**NOTE:** Refer to the Service Manual for more detail on maintenance and service repairs.

### LUBRICATING THE MACHINE

Regularly scheduled lubrication of certain machine parts should be performed to insure trouble-free operation of the machine. *Apply a generous amount of grease into the fittings on the machine until grease seeps out around the bearings.*

The grease points are listed below:

- Rear squeegee caster wheel axle (2)
- Rear squeegee caster wheel stem (2)
- Side squeegee caster wheel axle (2)
- Side squeegee caster wheel stem (2)
- Steering wheel chain sprockets and idlers

Apply lubricant or light machine oil to lubricate the:

- Rear squeegee general pivot points
- Side squeegee general pivot points
- Scrub deck linkages
- Drive wheel assembly seals.

## GENERAL MACHINE TROUBLESHOOTING

Problem	Possible Cause	Remedy
<b>Poor water pick-up</b>	Worn or torn squeegee blades	Rotate or replace blades
	Squeegee out of adjustment	Adjust so blades touch floor evenly across entire width
	Recovery tank full	Empty recovery tank
	Recovery tank drain hose leak	Secure drain hose cap or replace
	Recovery tank lid gasket leak	Replace gasket lid cover properly
	Debris caught in squeegee	Clean squeegee
	Vacuum hose clogged	Remove debris and flush hose
	Using too much solution	Adjust solution control valves
	Vacuum hose to squeegee or recovery tank disconnected to squeegee or damaged	Reconnect or replace squeegee hose
<b>Poor scrubbing performance</b>	Worn brushes	Rotate or replace brushes
	Wrong brush or cleaning chemical	Consult Minuteman
	Debris caught on scrub brushes	Remove debris
	Moving machine too fast	Slow down
	Not using enough solution	Adjust solution flow setting
	Low battery charge	Recharge batteries
	Fault code on LCD screen 760x (Brush motor)	Reduce scrub brush pressure.  Broken brush drive belts on cylindrical system, replace belt(s).  Check power connection. Reconnect plugs.  Reset machine: Turn key switch off and restart.
<b>Inadequate solution flow or no solution to the floor</b>	Solution tank empty	Fill solution tank
	Recovery tank full	Empty recovery tank
	Solution lines, valves, filter or spray jets clogged	Flush lines, and clean solution filter and spray jets.
	Solution solenoid valve	Clean or replace valve
<b>No solution to off-aisle wand spray jet</b>	Recovery tank full	Empty recovery tank
	Solution tank empty	Refill solution tank
<b>Machine does not run</b>	Emergency stop switch tripped	Activate switch by turning as indicated by arrows.
	Operator seat safety switch	Operator has to be seated. Check for open circuit and replace
	Main system controller	Check error fault codes <b>(See service manual)</b>
	Tripped 100 amp circuit breaker	Check for electrical short circuit Reset machine: Rest breaker and turn key switch off and restart.
<b>No FWD/REV drive</b>	Drive system speed controller. Fault code on LCD screen 780x (Traction motor)	Check error fault codes <b>(See service manual)</b> Reset machine: Turn key switch off and restart.
	Emergency stop switch tripped	Activate switch by turning as indicated by arrows.

<b>Vacuum motor does not turn on</b>	Recovery tank full	Empty recovery tank
	Excessive foaming in recovery tank.	Empty recovery tank.  Use less or change chemical.  Use defoaming agent.
	Fault code on LCD screen 7700 (Vacuum motor)	Check for motor overload.  Reset machine: Turn key switch off and restart.
<b>Poor sweeping performance</b> (Cylindrical System)	Debris box full	Empty and clean debris box
	Brushes worn	Replace brushes
	Bristles have taken a set	Rotate brushes
<b>Solution tank empty indicator light on</b>	Solution tank empty	Refill solution tank
	Faulty float switch	Replace float switch
<b>Recovery tank full indicator light on</b>	Recovery tank. full	Empty recovery tank.
	Float switch full of debris	Clean float switch.
	Faulty float switch	Replace float switch

**SCV 28/32 FAULT / DIAGNOSTIC CODES**

<b>Code</b>	<b>Technical Description</b>	<b>Probable Cause</b>	<b>Service Action</b>
<b>0705</b>	2.5V reference error	All 070x codes – Wiring short circuit between potentiometer Hi and Lo reference.	Check for wiring short circuits on the 20-way connector on the SCV, the 16-way connector on the LCD (if used) and the wiring to the front panel switches & controls and those switches & controls themselves.
<b>0706</b>	High switch reference error		
<b>0810</b>	Potentiometer Fault 1	All 081x codes – Throttle wiring short or open circuits.	Check for wiring short circuits or broken wires on the 20-way connector on the SCV, the 5 way connector on the LCD (if used) and the wiring to the front panel speed / throttle control and the speed / throttle control itself.
<b>1500</b>	Brake fault 1	All 150x codes – Check brake and wiring for open or short circuit.	Check the traction motor connection on the SCV and check the wiring from this connector down to the traction motor and checking connections all the way. Otherwise possible fault in electro brake on traction motor or possible controller fault.
<b>1600</b>	High battery voltage	Voltage exceeds maximum.	Can be caused by poor or corroded connections to the batteries or a battery charger being connected.
<b>7500</b>	LCD Module communications timeout	Wiring fault on 6-way serial link between SCV and LCD	Check the wiring and connectors on the 6 way connections on the SCV and LCD.
<b>7600</b>	Brush motor disconnected error	Open circuit on brush motors or brush motor wiring.	Check the brush motor connection on the SCV and check the wiring from this connector down to the brush motor and checking connections all the way. Otherwise possible brush motor fault.
<b>7601</b>	Brush current foldback	Brush current overload (“thermal” trip).	Incorrect programming, incorrectly specified brush motor, brush motor developing a fault, excessive resistance on brushes or brushes pushing down too hard on floor.
<b>7700</b>	Vacuum motor disconnected error	Open circuit on vacuum motors or vacuum motor wiring.	Check the vacuum motor connection on the SCV and check the wiring from this connector down to the vacuum motor and checking connections all the way. Otherwise possible vacuum motor fault.
<b>7701</b>	Vacuum current foldback	Vacuum current overload (“thermal” trip).	Incorrect programming, incorrectly specified vacuum motor, vacuum motor developing a fault, debris in vacuum motor or airways blocked by debris.
<b>7800</b>	Motor fault 1	Open circuit on traction motor or traction motor wiring.	Check the traction motor connection on the SCV and check the wiring from this connector down to the traction motor and checking connections all the way. Otherwise possible traction motor fault.
<b>7801</b>	Traction over current error	Possible short circuit on traction motor or wiring.	Check the traction motor connection on the SCV and check the wiring from this connector down to the traction motor and checking connections all the way. Otherwise possible traction motor fault.

<b>7802</b>	Traction motor in foldback state	Traction motor current has exceeded current limit for the foldback time.	Excessive driving up an incline, or machine driven up against an obstacle or step.
<b>7900</b>	Emergency stop error	E-stop input active or wiring fault.	Check for wiring short circuits on the 20-way connector on the SCV, the 16-way connector on the LCD (if used) and the wiring to the emergency stop switch and the emergency stop switch itself. Otherwise incorrect operation of machine.
<b>2C00</b>	Low battery error	Low voltage warning.	Recharge batteries immediately.
<b>2F01</b>	Potentiometer displace error	Throttle in drive position during switch on.	Incorrect operation of machine. Otherwise check the mechanical condition of the throttle mechanism. Otherwise check for wiring short circuits on the 20-way connector on the SCV, the 16-way connector on the LCD (if used) and the wiring to the front panel switches & controls and those switches & controls themselves.

MAIN ASSEMBLY I

EXPLODED VIEWS

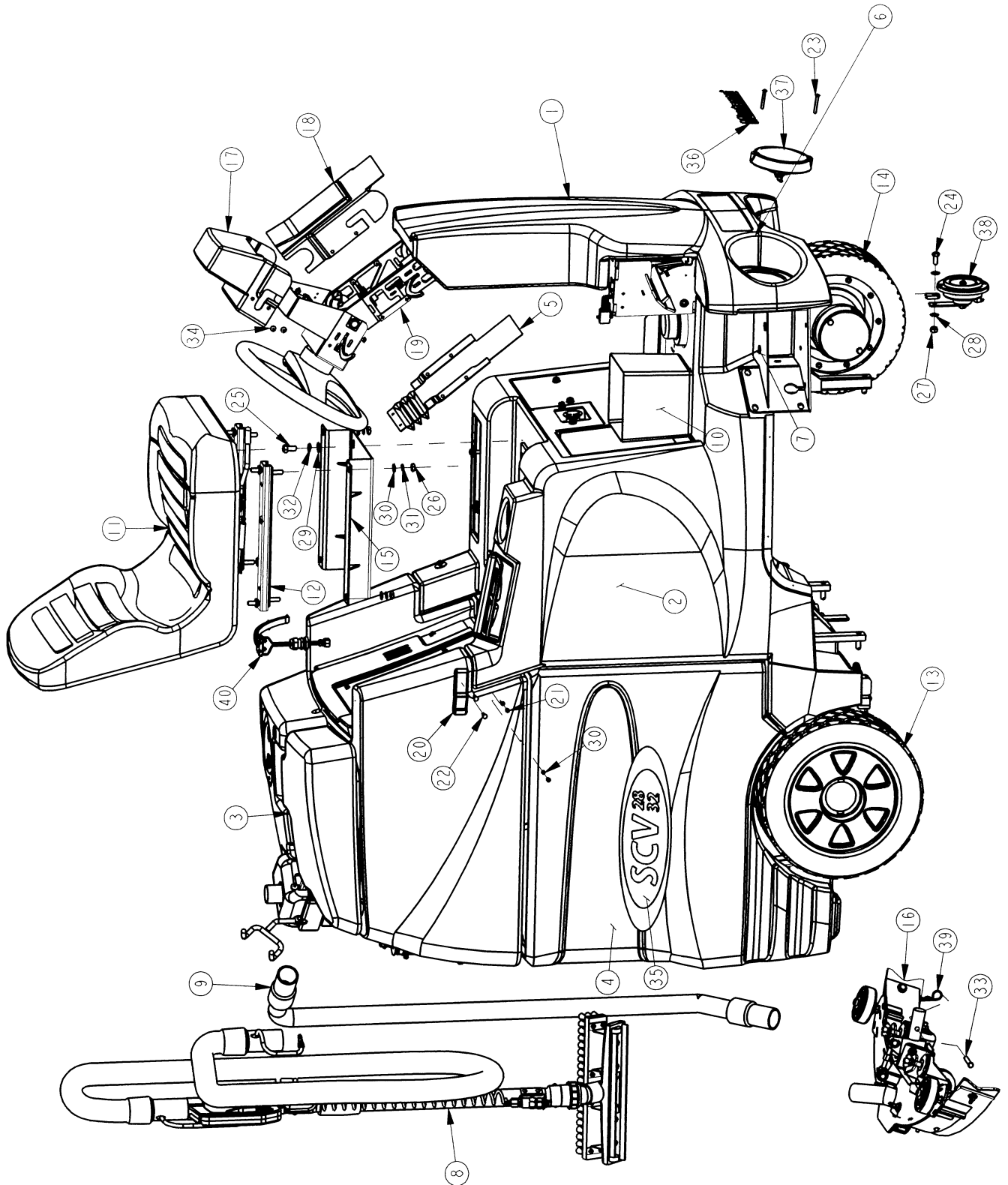

BILL OF MATERIAL			
ITEM	PART NO.	REQ'D	DESCRIPTION
1	281001	1	BUMPER FRONT
2	281012	1	SOLUTION TANK ASS'Y - SCV 28/32
3	281013	1	2800 RECOVERY TANK SUB-ASSY
4	281014	1	BATTERY TRAY ASSY
5	281030	1	STEERING COVER, BOTTOM
6	281066	1	ANTISKID STEP, LH
7	281067	1	ANTISKID STEP, RH
8	281071	1	OFF AISLE WAND ASSY, 2800
9	281078	1	HOSE ASSY - SQUEEGEE, SCV 28/32
10	281083	1	TOOL BUCKET, 2800
11	281085	1	ASS'Y SEAT, SUPER SUBURBAN
12	281086	1	SLIDE ASS'Y KIT
13	281201	1	REAR AXLE ASSY
14	281251	1	FRONT DRIVE ASSY
15	281376	1	28 SEAT BRACKET WMT
16	281701	1	REAR SQUEEGEE ASSY, 2800
17	282028	1	STEERING COVER, MAIN
18	282029	1	STEERING COVER, TOP
19	282301	1	STEERING ASSEMBLY, NEW SCV
20	450207	2	LATCH, SOFT #C7-10

BILL OF MATERIAL			
ITEM	PART NO.	REQ'D	DESCRIPTION
21	710328	4	SCR-MC 8-32 X .37 ST PL - ROUND HEAD
22	711161	4	SCR HI/LO #10 X 3/4 PL
23	711162	4	#10 X 1-1/2 HI-LO
24	711228	1	BLT-HH 5/16-18 X .75 ST PL
25	711241	4	SCR-HEX 3/8 -18X .75" ZP
26	711319	4	5/16-18 HEX NUT
27	711374	1	NUT-NYLOC 5/16-18
28	711506	6	WSR-FLT .344 X .690 X .062 STL ZINC
29	711515	4	WSR-FLAT .406 X .812 X .0625
30	711542	4	WSR-HELICAL #8
31	711545	4	WSR-HELICAL 5/16
32	711546	4	WSR-HELICAL 3/8
33	711671	1	CLEVIS PIN .31X2.13 11-10
34	712816	10	SCR-MC 10-24 X .37 STPL
35	715298	2	DECAL, SCV 28/32
36	715385	1	MINUTEMAN LOGO 1.4 X 9.6
37	742704	2	HEADLIGHT, 36V ROUND ASSY
38	748016	1	HORN, 36/48V, 2800
39	833374	1	HAIRPIN COTTER 3/8
40	281087-1	1	SWITCH, SEAT



MAIN ASSEMBLY II

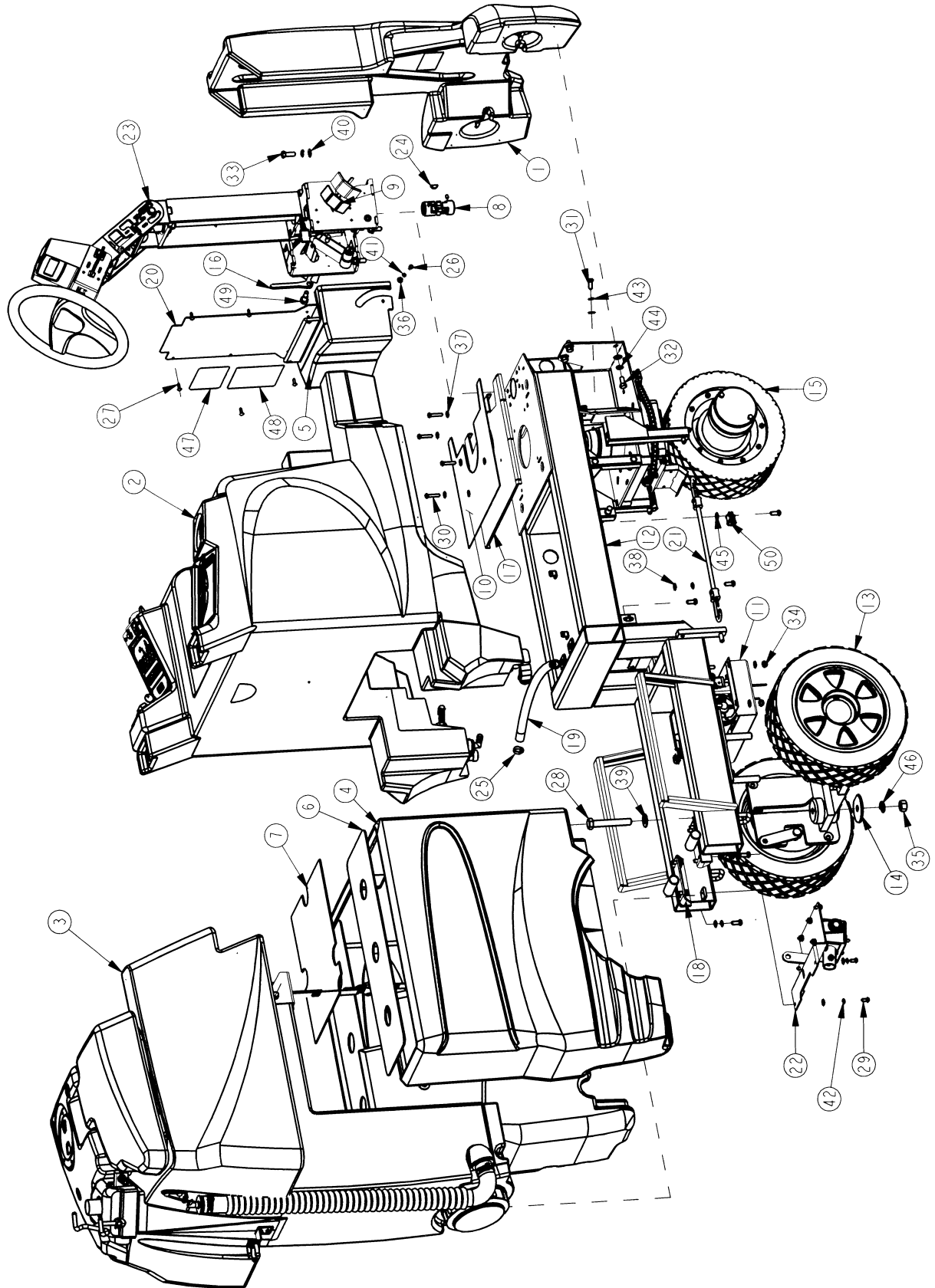

BILL OF MATERIAL			
ITEM	PART NO.	REQ'D	DESCRIPTION
1	281011	1	FRONT BUMPER ASM
2	281012	1	SOLUTION TANK ASSY - SCV 28/32
3	281013	1	2800 RECOVERY TANK SUB-ASSY
4	281014	1	BATTERY TRAY ASSY
5	281024	1	STEERING COLUMN COVER - BOTTOM
6	281026	2	2800 BATTERY COVER SIDE
7	281027	1	2800 BATTERY COVER CENTER
8	281051	1	SPIDER COUPLING, 3/4"
9	281065	2	ANTISKID PEDAL
10	281068	1	ANTISKID FLOOR
11	281098	1	PUMP SUB-ASSEMBLY
12	281101	1	MAINFRAME WMT, 28" SCRUBBER
13	281201	1	REAR AXLE ASSY
14	281211	4	SNUBBING WSR
15	281251	1	FRONT DRIVE ASSY
16	281341	1	BRAKE PARK HANDLE
17	281351	1	FLOOR PANEL WELDMENT
18	281360	2	FIXED SLIDER WELDT
19	281428	1	SOLUTION BALANCE HOSE
20	281429	1	STEERING COLUMN REAR COVER - TOP
21	281445	1	BUNGEE CORD - 16"
22	281702	1	2800 SQUEEGEE MECH ASSY
23	282301	1	STEERING ASSEMBLY, NEW SCV
24	363277	2	KEY WOODRUFF 3/16 X 3/4
25	363347	2	CRIMP CLAMP 1/2 HOSE SS 185R

BILL OF MATERIAL			
ITEM	PART NO.	REQ'D	DESCRIPTION
26	710356	2	SCR-MC 10-32X.62 STPL
27	711160	6	#10 X 5/8 HI-LO
28	711173	4	BLT-HH 5/8-11 X 4 (GR 5)
29	711202	4	BLT-HH 1/4-20 X 0.50 STPL
30	711210	4	BLT-HH 1/4-20 X 1.25 STPL
31	711228	17	BLT-HH 5/16-18 X .75 ST PL
32	711241	6	SCR-HEX 3/8 -16X .75" ZP
33	711242	6	BLT-HEX 3/8 -16X1.00 ZP
34	711374	4	NUT-NYLOC 5/16-18
35	711445	4	NUT HEX 5/8 X 11 PLATED
36	711503	2	WSR, FLAT#10
37	711505	8	WSR-FLAT 1/4
38	711506	20	WSR-FLT .344 X .690 X .062 STL ZINC
39	711511	4	WSR-FLAT .62 X 1.31 X .09
40	711515	12	WSR-FLAT .406 X .812 X .0625
41	711534	2	WSR-EXTERNAL LOCK #10
42	711544	4	WSR-HELICAL 1/4
43	711545	16	WSR-HELICAL 5/16
44	711546	12	WSR-HELICAL 3/8
45	711575	1	WSR-FLT .31x.75x.06ST
46	712315	4	WSR-HELI .64 X 1.28 X .06 PL
47	715901	1	WARNING DECAL, TANK LATCH
48	715903	1	SCV FAULT CODES, DECAL
49	712099PLT	1	BLT- SHLDR 1/2 X 5/8
50	82-54-A	1	CLAMP, MS21333-114

# MAINFRAME ASSEMBLY I

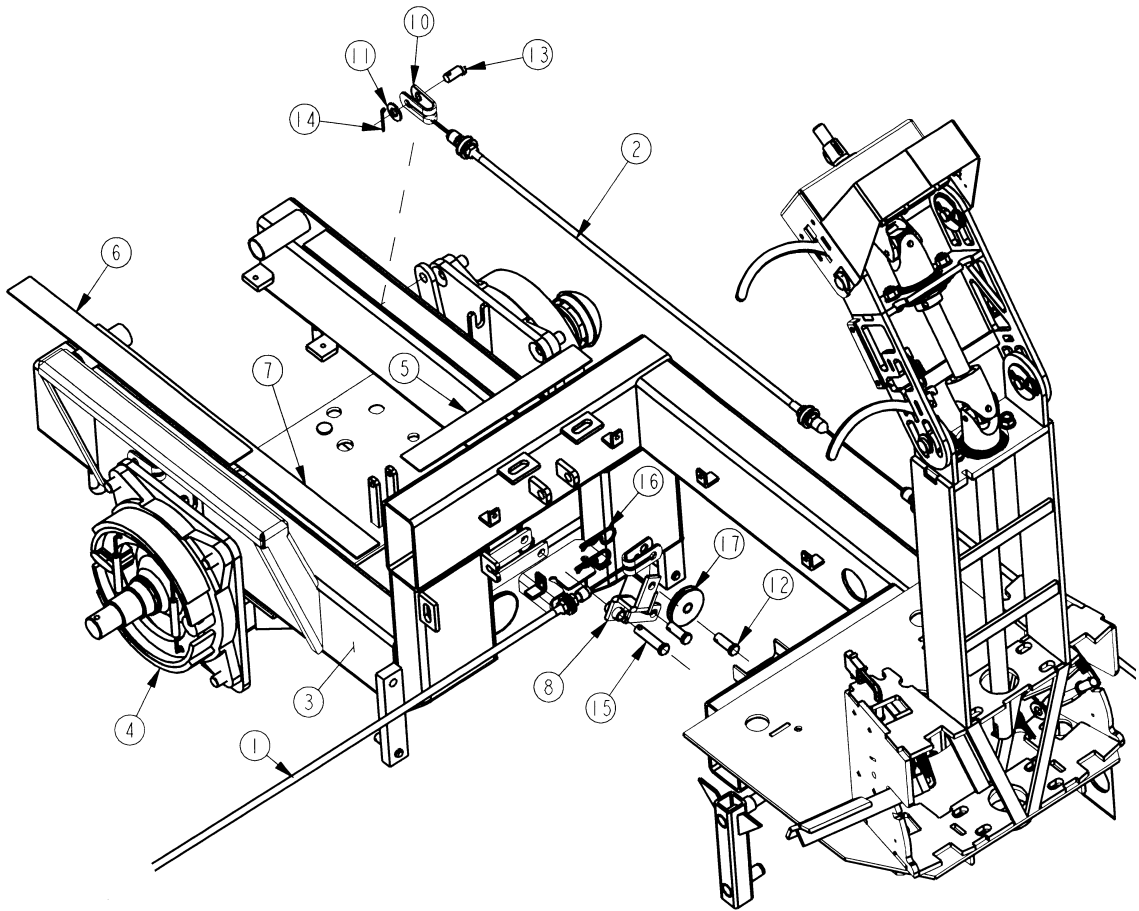

BILL OF MATERIAL			
ITEM	PART NO.	REQ'D	DESCRIPTION
1	281062	1	2800 FRONT BRAKE CABLE
2	281063	1	2800 REAR BRAKE CABLE
3	281101	1	MAINFRAME WMT, 28" SCRUBBER
4	281201	1	REAR AXLE ASSY
5	281468	1	FRICTION STRIP 9.50"
6	281469	2	FRICTION STRIP 14.25"
7	281470	2	FRICTION STRIP 18.00"
8	281485	1	FOOT BRAKE PULLEY ARM WELDMENT
9	282301	1	STEERING ASSEMBLY, NEW SCV
10	320248	3	CLEVIS, SLOTTED
11	711515	3	WSR-FLAT .406 X .812 X .0625
12	711668	2	CLEVIS PIN, 3/8X1 11-141
13	711679	2	CLEVIS PIN 3/8 X 3/4
14	809311	2	PIN-COTTER 7/64 DIA X 1
15	831965	1	3/8 x 1.63" CLEVIS PIN
16	833374	4	HAIRPIN COTTER 3/8
17	81-44-A	1	NYLON PULLEY

MAINFRAME ASSEMBLY II

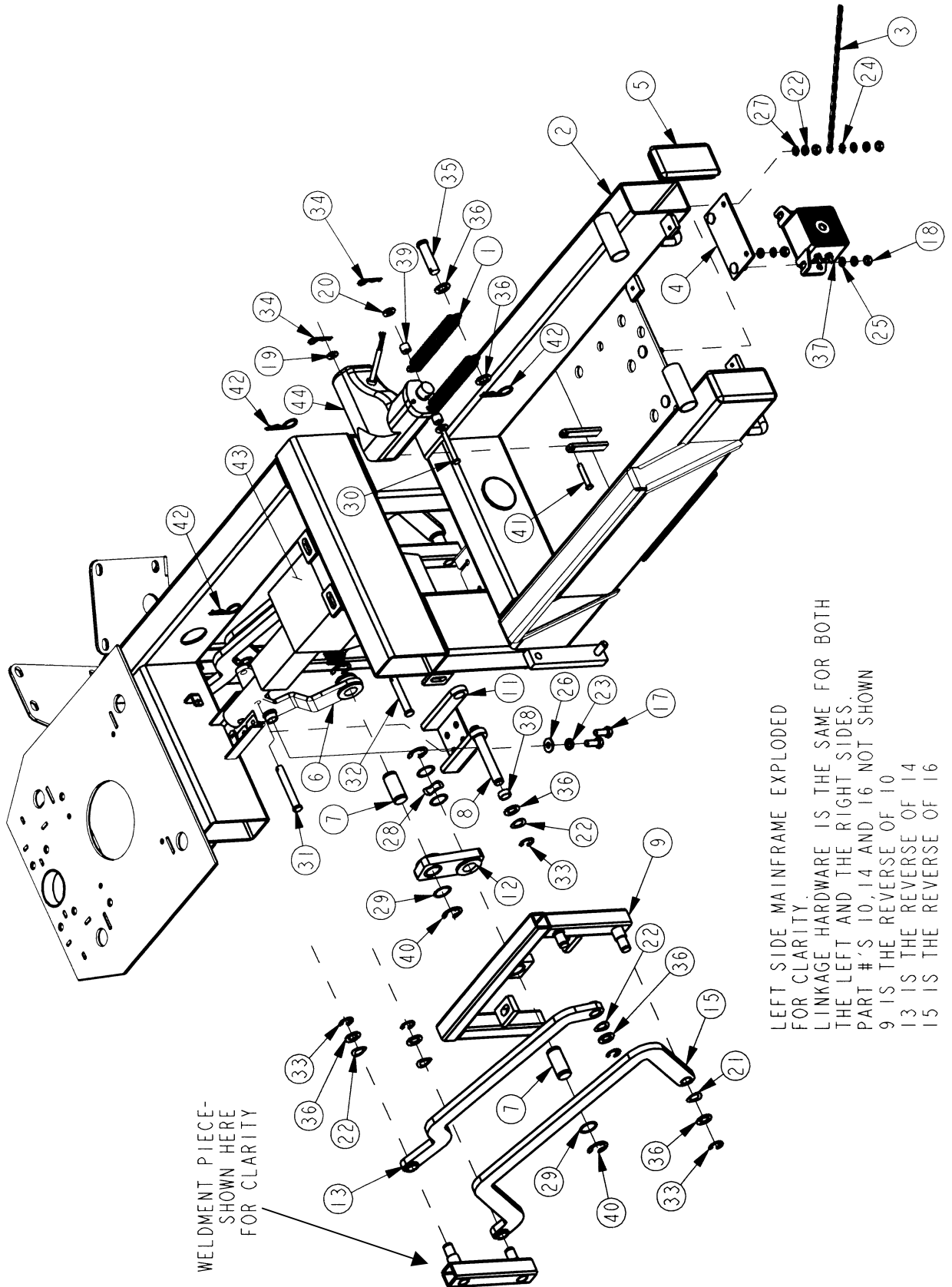

BILL OF MATERIAL LINKAGE ASSY			
ITEM	PART NO.	REQ'D	DESCRIPTION
1	281046	2	SPRING, EXTENSION - 4.50"
2	281101	1	MAINFRAME WMT, 28" SCRUBBER
3	281200	1	DRAG CHAIN ASSY, FRAME
4	281422	1	BACK-UP ALARM MTG PLATE
5	281446	2	ENDCAP, TUBING 2" X 4"
6	281451	1	CRANK WMT W/ BUSHING ASS'Y
7	281458	4	LINK ATTACHMENT SHAFT
8	281459	1	CRANK PIVOT SHAFT
9	281461	1	LIFT WMT LH W/ BUSHING ASS'Y
10	281463	1	LIFT WMT RH W/ BUSHING ASS'Y
11	281471	1	ACTUATOR ATM'T WMT W/ BUSHING ASS'Y
12	281475	2	LIFT LINK ASS'Y
13	281477	1	UPPER LINK ASS'Y, LEFT
14	281478	1	UPPER LINK ASS'Y, RIGHT
15	281479	1	LOWER LINK ASS'Y, LEFT
16	281480	1	LOWER LINK ASS'Y, RIGHT
17	711228	4	BLT-HH 5/16-18 X .75 ST PL
18	711316	5	NUT-HEX 1/4-20 ST PL
19	711505	1	WSR-FLAT 1/4
20	711506	2	WSR-FLT .344 X .690 X .062 STL ZINC
21	711524	10	WSR-WAVE .52 X .87 X .01
22	711544	5	WSR-HELICAL 1/4

BILL OF MATERIAL LINKAGE ASSY			
ITEM	PART NO.	REQ'D	DESCRIPTION
23	711545	4	WSR-HELICAL 5/16
24	711564	1	WSR-EXTERNAL LOCK 1/4
25	711566	2	WSR-FLAT .259 X .500 X .07
26	711575	4	WSR-FLT .31x.75x.06ST
27	711577	3	WSR-FLAT 260 X .50 X .020THK
28	711583	4	WSR-WAVE .78 X 1.00 X .02
29	711588	12	WSR-FLAT .75X1.00X.025
30	711675	1	CLEVIS PIN 1/4 X 1-7/8
31	711677	1	CLEVIS PIN 3/8 X 2-5/8
32	711678	1	CLEVIS PIN 3/8 X 2-1/4
33	711713	10	RETAINING RING - "E" TYPE EXT .500
34	711808	2	COTTER PIN-HAIR #13
35	712109	1	CLEVIS PIN, 1/2 x 1-3/4
36	712310	12	WSR- FLAT .52 X .87 X .06 PL
37	748142	1	BACK-UP ALARM
38	762340	2	BUSHING .50 X .62 X .27
39	762371	2	BUSHING .260X.50X.37
40	809148	8	RETAINING RING - "E" TYPE EXT .75
41	832374	1	CLEVIS PIN, 1/4 x 1-3/8
42	833374	3	HAIRPIN COTTER 3/8
43	742712-2	1	ACTUATOR BRUSH, W/WEATHER PACK
44	748008-1	1	ACTUATOR, W/WEATHER PACK SCV SQUEEGEE

# FRONT DRIVE ASSEMBLY

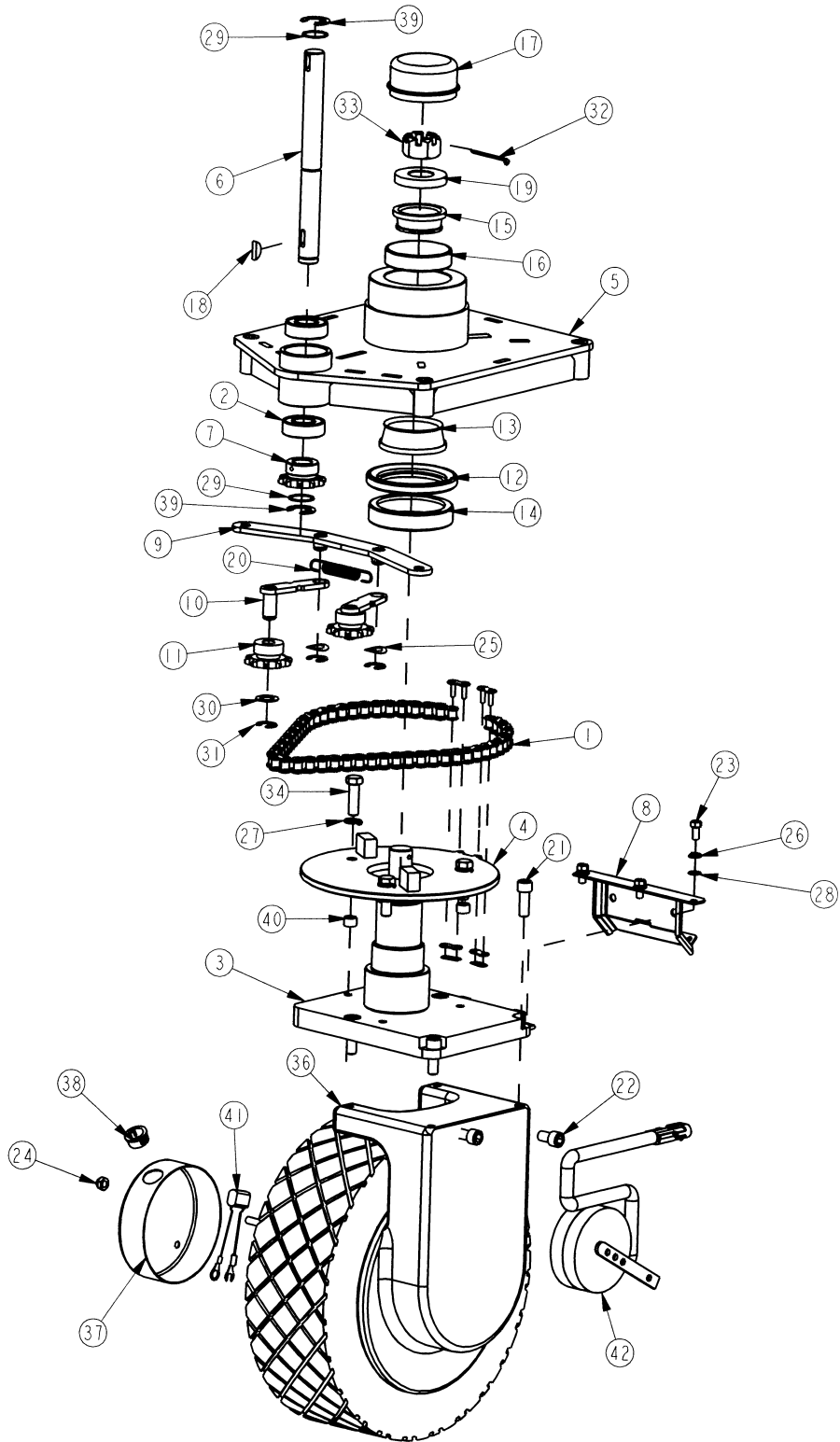

<b>BILL OF MATERIAL 281251</b>			
<b>ITEM</b>	<b>PART NO.</b>	<b>REQ'D</b>	<b>DESCRIPTION</b>
1	281054	1	CHAIN, STEERING No. 40, 27.5"
2	281057	2	BEARING 3/4" RADIAL
3	281252	1	SPINDLE WMT
4	281254	1	STEERING DISC WMT
5	281260	1	MOUNT WMT, FRONT DRIVE
6	281267	1	STEERING SPROCKET SHAFT
7	281268	1	SPROCKET-RC #40, 10 TEETH, 3/4" BORE
8	281272	1	WIRE MTG BRKT WMT, SCV/FD
9	281276	1	IDLER BASE WMT, FRONT DRIVE
10	281279	2	IDLER ARM WMT, FRONT DRIVE
11	281282	2	IDLER SPROCKET-RC #40, 10 TEETH
12	383074	1	SPINDLE SEAL
13	383075	1	BEARING CONE (LM104949)
14	383076	1	BEARING CUP (LM104911)
15	383077	1	BEARING CONE (LM104949)
16	383078	1	BEARING CUP (LM104911)
17	383250	1	GREASE CAP
18	383277	1	KEY WOODRUFF 3/16 X 3/4
19	383364	1	THRUST WASHER
20	430051	1	RETURN SPRING-3.00"
21	710858	4	SCR-SC 3/8-16 X 1.00
22	710991	2	SCR-SC 3/8-24 X 5/8 ST PL
23	711202	3	BLT-HH 1/4-20 X 0.50 STPL
24	711352	2	NUT-ACORN 1/4-20 ST N1
25	711524	2	WSR-WAVE .52 X .87 X .01
26	711544	3	WSR-HELICAL 1/4
27	711546	3	WSR-HELICAL 3/8
28	711577	3	WSR-FLAT 260 X .50 X .020THK
29	711588	2	WSR-FLAT .75X1.00X.025
30	711594	2	WSR-FLAT .56 X .88 X .03
31	711713	4	RETAINING RING - "E" TYPE EXT .500
32	711807	1	COTTER PIN .12 X 1.75
33	712113	1	CASTLE NUT
34	713043	3	BLT-HH 3/8-16 X 1 1/4 #5
35	740099	5	CABLE TIE - SMALL
36	748010	1	IMPERIAL ELEC CHASSISDRIVE 12"
37	748049	1	IMPERIAL DRIVE COVER
38	748122	1	BUSHING, HEYCO 2103 I.D .625.
39	809148	2	RETAINING RING - "E" TYPE EXT .75
40	809247	3	STEERING PLATE SPACER
41	744016-1	2	CAP .15 MICROFARAD 5/16R-1/4FORK
42	748010-3	1	E MAG BRAKE ASSY

# STEERING ASSEMBLY

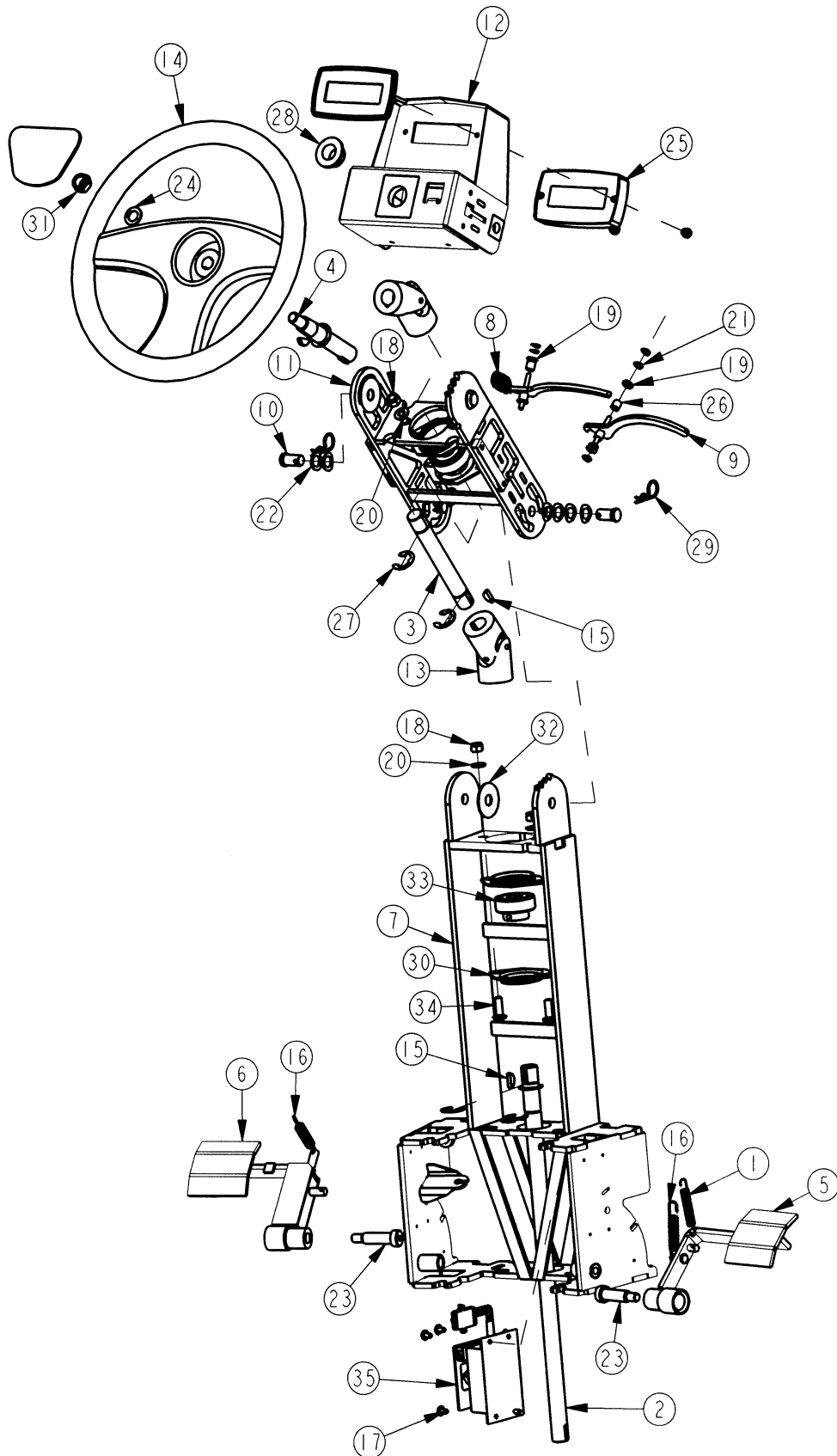



<b>BILL OF MATERIAL 282301</b>			
<b>ITEM</b>	<b>PART NO.</b>	<b>REQ'D</b>	<b>DESCRIPTION</b>
1	281047	1	SPRING, EXTENSION - 2.75"
2	281328	1	SHAFT, LOWER STEERING
3	281329	1	SHAFT, MIDDLE STEERING
4	281330	1	SHAFT, UPPER STEERING
5	281331	1	ACCEL PEDAL WMT
6	281335	1	BRAKE PEDAL WMT
7	282302	1	STEERING WELDMENT, LOWER
8	282303	2	SPRING - EXTENSION 1.375" F.L.
9	282309	2	ADJUSTMENT LEVER AND PIVOT PIN ASSY
10	282313	4	CLEVIS PIN, 1/2" DIA X .875" LG
11	282315	1	STEERING WELDMENT, MIDDLE
12	282321	1	UPPER BRACKET WELDMENT, STEERING COLUMN
13	383098	2	UNIVERSAL JOINT
14	383152	1	STEERING WHEEL
15	383277	5	KEY WOODRUFF 3/16 X 3/4
16	430051	2	RETURN SPRING-3.00"
17	710153	4	SCR-MC 10-32X.63 TH ZINC
18	711374	4	NUT-NYLOC 5/16-18
19	711503	4	WSR, FLAT#10
20	711506	4	WSR-FLT .344 X .690 X .062 STL ZINC
21	711521	8	WSR-WAVE .21 X .44 X .02
22	711524	16	WSR-WAVE .52 X .87 X .01
23	712102	2	BLT- SHLDR 1/2 X 1-1/2
24	712310	1	WSR- FLAT .52 X .87 X .06 PL
25	748005	1	LCD CONTROL PANEL MODULE
26	762384	4	BUSHING, SS .277 X .375 X .37
27	809148	6	RETAINING RING - "E" TYPE EXT .75
28	832554	1	BUSHING, FLANGE
29	833374	4	HAIRPIN COTTER 3/8
30	340742MCH	4	BEARING FLANGE, SHEARED
31	363-816	1	NUT NYLOC 1/2-20
32	58-05-A	4	WSHR-FLAT, .515" DIA X 1.625" OD X .070" THK
33	66-138-A	2	BEARING, 3/4"
34	70-516-16	4	BLT-CAR 5/16-18 X 1.00
35	748013-1	1	POTENTIOMETER BOX ASSEMBLY

# SOLUTION TANK ASSEMBLY

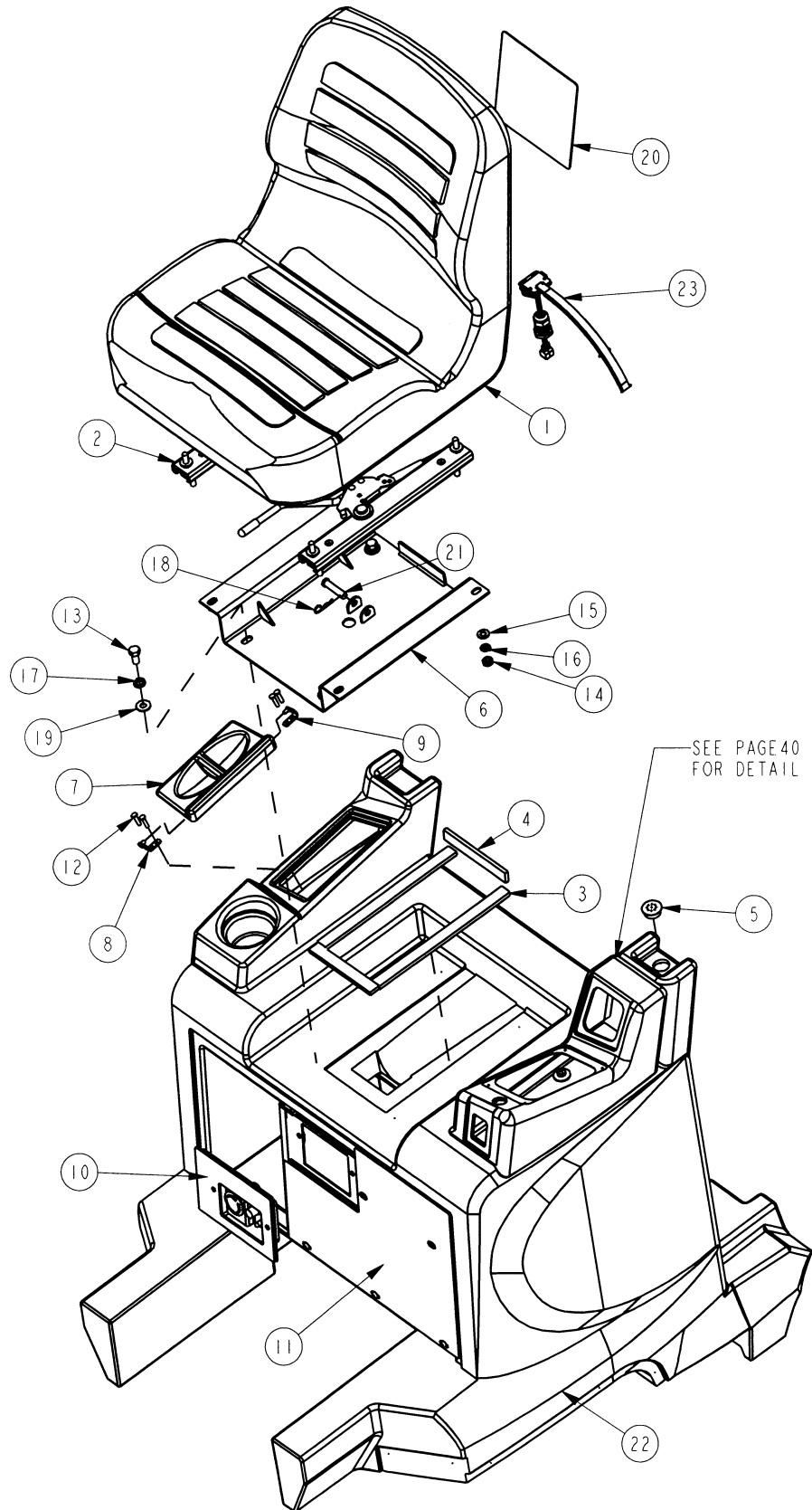

<b>BILL OF MATERIAL 281012</b>			
<b>ITEM</b>	<b>PART NO.</b>	<b>REQ'D</b>	<b>DESCRIPTION</b>
1	281085	1	ASS'Y SEAT, SUPER SUBURBAN
2	281086	1	SLIDE ASS'Y KIT
3	281363	2	SEAT GASKET - LONG
4	281364	2	SEAT GASKET - SHORT
5	281371	1	VENT PLUG
6	281376	1	28 SEAT BRACKET WMT
7	281380	1	SOLUTION TANK PLASTIC COVER
8	281381	1	SOLN TANK HINGE SUB-ASSY - RIGHT
9	281382	1	SOLN TANK HINGE SUB-ASSY -LEFT
10	281401	1	E-STOP ASS'Y
11	281407	1	ELECTRICAL PANEL ASS'Y SCV 28/32
12	711161	4	SCR HI/LO #10 X 3/4 PL
13	711241	4	SCR-HEX 3/8 -16X .75" ZP
14	711319	4	5/16-18 HEX NUT
15	711506	4	WSR-5/6 STPL
16	711545	4	WSR-HELICAL 5/16
17	711546	4	WSR-HELICAL 3/8
18	711808	1	COTTER PIN-HAIR #13
19	712301	4	WSR-FLAT .87 X .38 X .06
20	715902	1	DECAL, SCV BATTERY
21	831965	1	3/8 x 1.63" CLEVIS PIN
22	281012-1	1	SOL TANK / CONSOLE SUB-ASSY
23	281087-1	1	SWITCH, SEAT

## SOLUTION TANK ASSEMBLY II

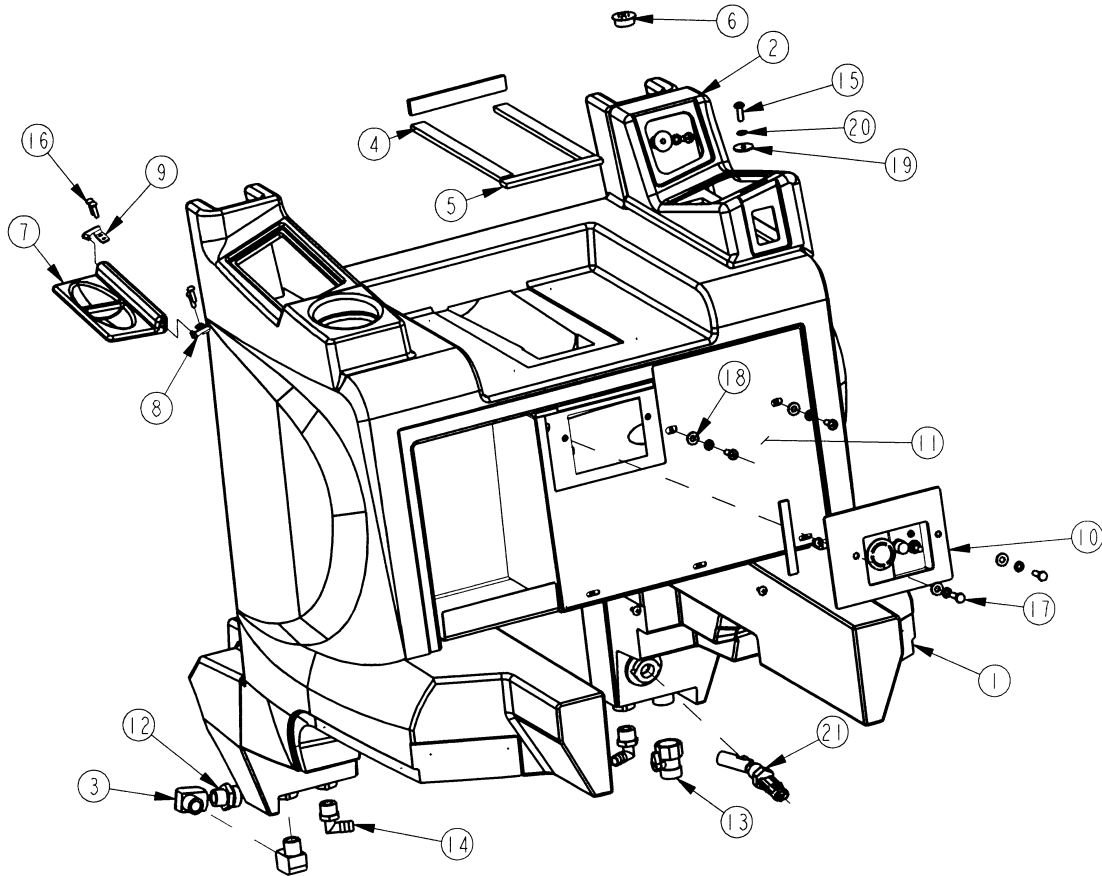

BILL OF MATERIAL			
ITEM	PART NO.	REQ'D	DESCRIPTION
1	281002	1	SOLUTION TANK - 2800
2	281005	1	SCV 28/32 CONSOLE
3	281093	2	FITTING STREET 90 1/2 x 1/2 BRS
4	281363	2	SEAT GASKET - LONG
5	281364	2	SEAT GASKET - SHORT
6	281371	1	VENT PLUG
7	281380	1	SOLUTION TANK PLASTIC COVER
8	281381	1	SOLN TANK HINGE SUB-ASSY - RIGHT
9	281382	1	SOLN TANK HINGE SUB-ASSY - LEFT
10	281401	1	E-STOP ASS'Y
11	281407	1	ELECTRICAL PANEL ASS'Y SCV 28/32
12	281426	1	COUPLING 3/4" HOSE X 1/2" MPT
13	281427	1	#35 SHUTOFF, BLACK, ZERO PRS
14	383449	2	ELBOW 1/2 MPT X 1/2 BARB
15	710380	5	SCR-MC 1/4-20 X .75 ST PL
16	711161	4	SCR HI/LO #10 X 3/4 PL
17	711206	2	BLT-HH 1/4-20 X .87 ST PL
18	711505	4	WSR-FLAT 1/4
19	711519	3	WSR- FLAT .25 X 1.01 X .06
20	711544	7	WSR-HELICAL 1/4
21	742708-4	1	FLOAT SWITCH W/WEATHER PACK

## ELECTRICAL PANEL ASSEMBLY

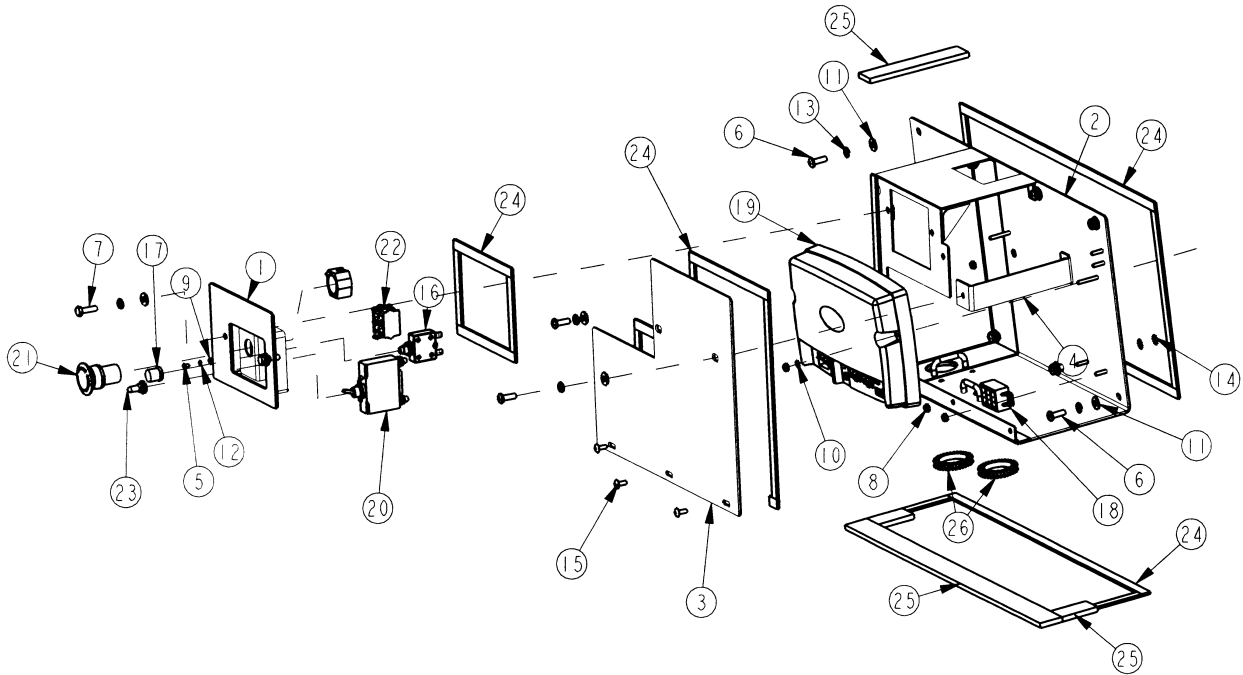

BILL OF MATERIAL			
ITEM	PART NO.	REQ'D	DESCRIPTION
1	281402	1	E-STOP WELDMENT
2	281408	1	ELECTRICAL PANEL WMT, 2800
3	281412	1	ELECTRICAL COVER PANEL
4	281430	1	ELECTRICAL CVR PNL SUPPORT BRKT
5	710202	1	SCR-MC 6-32 X .25 ST PL PAN HD
6	710380	10	SCR-MC 1/4-20 X .75 ST PL
7	711206	2	BLT-HH 1/4-20 X .87 ST PL
8	711372	6	NUT, HEX 8-32 NYLOC
9	711501	1	WSR-FLAT # 6
10	711502	4	WSR-FLAT # 8
11	711505	12	WSR-FLAT 1/4
12	711541	1	WSR-HELICAL #6 ST PL
13	711544	12	WSR-HELICAL 1/4
14	711564	2	WSR-EXTERNAL LOCK 1/4
15	712822	3	SCR-MC 10-24 X .50 TH SS
16	742350	1	CIRCUIT BREAKER 6 AMP
17	742748	1	CIRCUIT BREAKER BOOT
18	743032	1	TERMINAL BLOCK EAGLE 3
19	748004	1	CONTROLLER BOARD 36VDC
20	748012	1	CIRCUIT BREAKER 100A
21	748014	1	EMBERGENCY PUSHBUTTON ACTUATOR, 2800
22	748015	1	CONTACT BLOCK, 2800
23	748032	1	CIRCUIT BREAKER, BOOT FOR 748012
24	830557	11.25'	GASKET, DORTITE 1/2" RM .500 X .12
25	806006	2.7'	GASKET 1.25 X .250
26	281449	2	SERRATED GROMMET STRIP

## CONSOLE ASSEMBLY

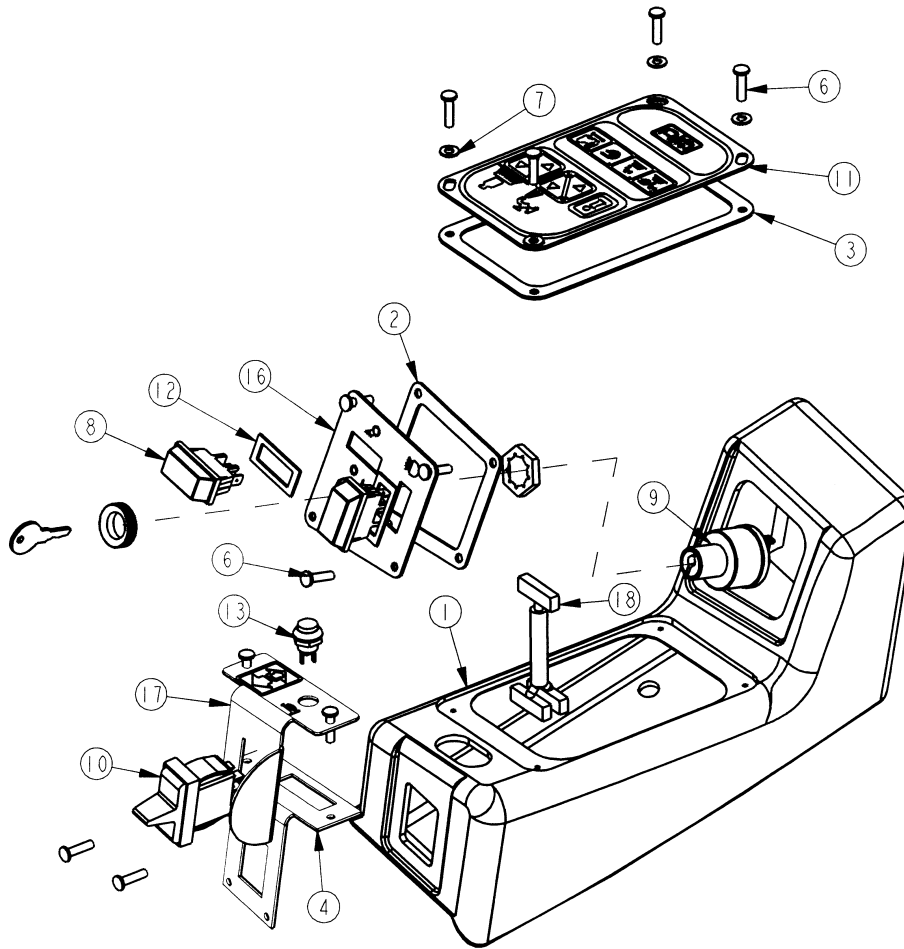

BILL OF MATERIAL			
ITEM	PART NO.	REQ'D	DESCRIPTION
1	281005	1	SCV 28/32 CONSOLE
2	281372	1	GASKET - IGNITION SWITCH PANEL
3	281373	1	GASKET - MEMBRANE SWITCH
4	281375	1	GASKET - DIRECTION SWITCH
5	281427	1	#35 SHUTOFF, BLACK, ZERO PRS
6	711161	12	SCR HI/LO #10 X 3/4 PL
7	712320	4	WSR-NYLON .22 X .45 X .04
8	742716	2	SWITCH DREEFS 1 POLE ON-OFF
9	742927	1	SWITCH, KEY 2 POLE
10	748000	1	SWITCH, PADDLE ON/NONE/ON
11	748011	1	MEMBRANE KEYPAD
12	748035	2	ROCKER SWITCH GASKET
13	748047	1	HORN SWITCH, SCV 36V
14	748126	1	GROUND STRAP (NOT SHOWN)
15	748128	1	GROUND WIRE (NOT SHOWN)
16	281378SP	1	IGNITION SWITCH PANEL
17	281379SP	1	DIRECTION CONTROL PANEL
18	748011-1	1	MEMBRANE KEYPAD HARNESS

# RECOVERY TANK ASSEMBLY I

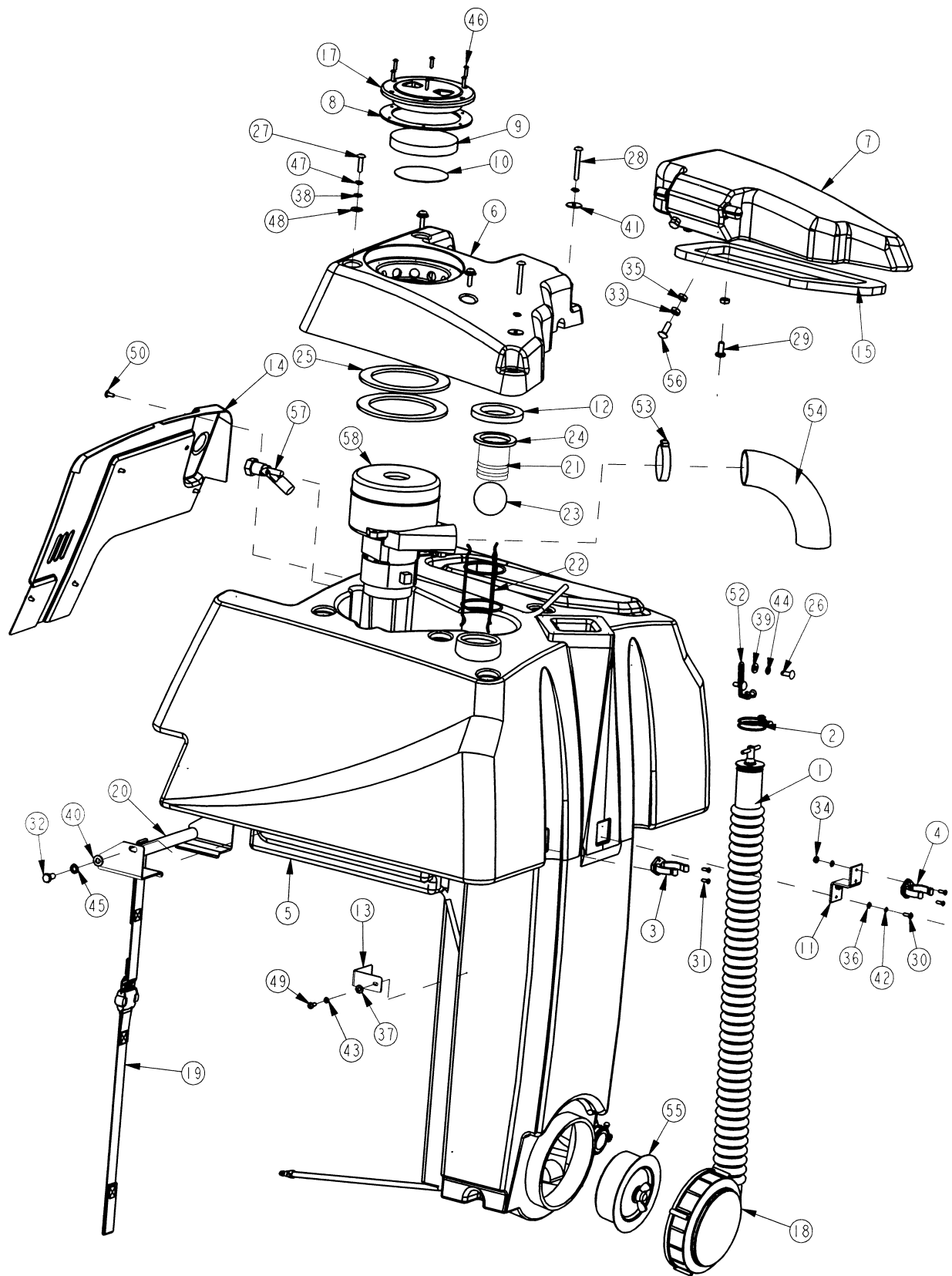

BILL OF MATERIAL 281010			
ITEM	PART NO.	REQ'D	DESCRIPTION
1	200289	1	DUMP HOSE ASM
2	260203	1	WIRE GRIP HOSE CLAMP
3	260579	1	TOOL CLIP, 1.5" HOSE
4	270161	1	TOOL CLIP
5	281003	1	RECOVERY TANK - 2800
6	281006	1	LID - FIXED 2800 RECOVERY TANK
7	281007	1	LID-MOVABLE 2800 RECOVERY TANK
8	281018	1	GASKET, NEO 6.00 X 4.50 X .125
9	281055	1	VAC MOTOR FILTER
10	281056	1	VAC MOTOR INLET SCREEN
11	281070	1	TOOL CLIP BRACKET
12	281073	1	INLET GASKET
13	281076	3	2800 REC TANK BRACKET
14	281099	1	WIRE COVER
15	281358	1	GASKET, MOVABLE LID - SCV
16	281391	1	SOL. FEED HOSE, OFF AISLE SUB-ASY
17	281423	1	FILL CAP W/CHAIN ASSY 4.00
18	281432	1	CAP 6", CLEAN OUT SCV
19	281433	1	SAFETY STRAP, REC TANK
20	281437	1	STRAP HOLDER WMT
21	281439	1	SHUTOFF FLANGE TUBE
22	281440	1	FLOAT CAGE, SCV
23	281442	1	FLOAT BALL, SCV
24	281950	1	FLOAT CAGE GASKET
25	380035	2	MOTOR GASKET
26	710180	2	SCR-MC 1/4-20X.75 TR HD
27	710189	3	SCR-MC 1/4-20 X 1.00 TRUSS PL SS
28	710190	2	SCR-MC 1/4-20 X 2.00 TRUSS PL SS
29	710197	2	SCR-MC 5/16-18 X .75 PHILLIPS
30	710329	2	SCR-MC 8-32 X .50 ST PL - ROUND HEAD
31	710530	4	SCR-MC 8-32 X .50 BR
32	711227	2	BLT-HH 5/16-18 X .62 ST PL
33	711319	5	5/16-18 HEX NUT
34	711372	2	NUT, HEX 8-32 NYLOC
35	711420	1	NUT- HEX JAM 5/16-18 ST PL
36	711502	4	WSR-FLAT # 8
37	711503	3	WSR, FLAT#10
38	711504	3	WSR-FLAT 1/4 ID SS
39	711505	2	WSR-FLAT 1/4
40	711506	2	WSR-FLT .344 X .690 X .062 STL ZINC
41	711519	2	WSR- FLAT .25 X 1.01 X .06
42	711542	2	WSR-HELICAL #8
43	711543	3	WSR - HELICAL #10
44	711544	2	WSR-HELICAL 1/4
45	711545	2	WSR-HELICAL 5/16
46	712516	6	SCR-BHCS #8-32 x .62 SS
47	712758	5	WSR-HELICAL 1/4 SS
48	712767	3	FLAT WASHER .406 ID X .75 OD X .
49	712811	3	SCR-MC 10-24 X .50 ST PL
50	712822	5	SCR-MC 10-24 X .50 TH SS
51	748099	1	WIRE ASSY, REC TANK
52	760286	1	HOOK, WIRE FORMED
53	760859	1	CLAMP, HOSE
54	833191	1	HOSE RUBBER FLEX 2 X 9
55	281444-1	1	STOPPER PLUG ASSY
56	70-516-16	2	BLT-CAR 5/16-18 X 1.00
57	742708-3	1	FLOAT SWITCH VACUUM WITH TERMINAL
58	742772-1	1	VACUUM ASSEMBLY, SCV



# RECOVERY TANK II

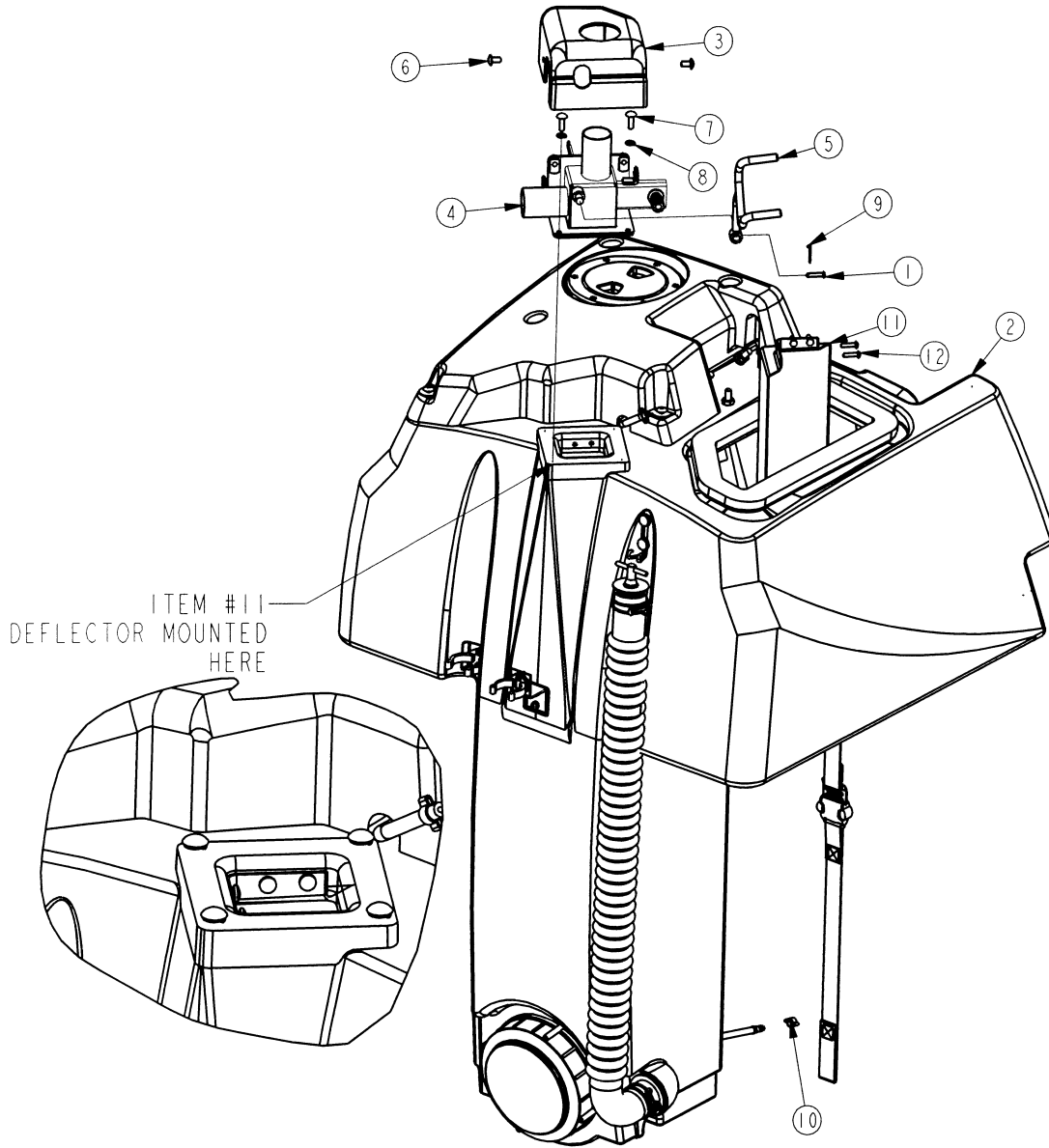

BILL OF MATERIAL 281013

ITEM	PART NO.	REQ'D	DESCRIPTION
1	270164	1	CLEVIS PIN, .188 X .875
2	281010	1	RECOVERY TANK / LID SUB-ASSEMBLY
3	281025	1	DIVERTER COVER
4	281801	1	DIVERTER ASSY, 2800
5	281806	1	DIVERTER HANDLE WMT, 2800
6	710178	2	SCR-MC 1/4-20 X .50 TRUSS STPL
7	710180	4	SCR-MC 1/4-20X.75 TR HD
8	711544	4	WSR-HELICAL 1/4
9	711803	1	COTTER PIN-HAIR
10	830082	1	HOSE CLAMP 3/8
11	281019	1	DIVERTER COVER
12	711161	4	SCR HI-LO #10 X 3/4

## DIVERTER ASSEMBLY

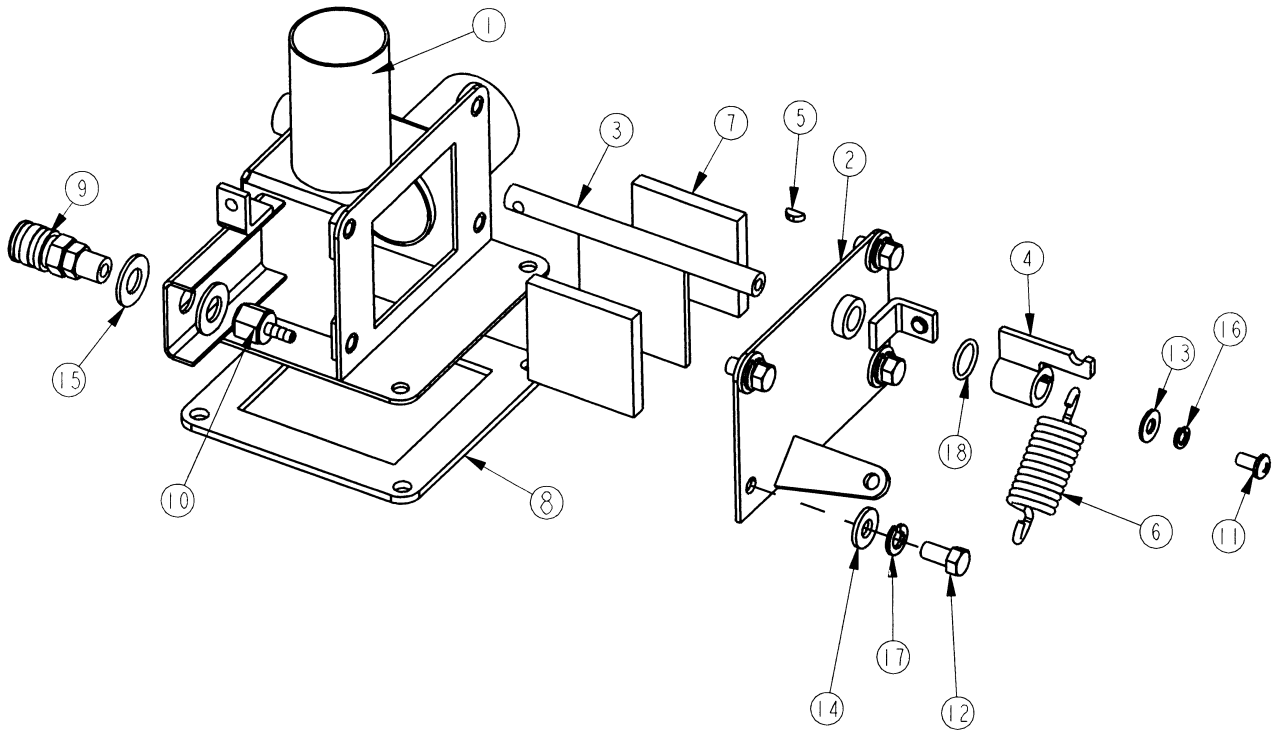

<b>BILL OF MATERIAL 281801</b>			
<b>ITEM</b>	<b>PART NO.</b>	<b>REQ'D</b>	<b>DESCRIPTION</b>
1	281802	1	DIVERTER HOUSING WMT ASSY, 2800
2	281803	1	DIVERTER SPRING PLATE WMT, 2800
3	281805	1	DIVERTER FLAPPER WMT, 2800
4	281807	1	DIVERTER SPRING ATTACH WMT, 2800
5	281819	1	KEY-WOODRUFF TYPE 302.5 (FBT)
6	281821	1	SPRING, EXTENSION - 2.25"
7	281823	2	GASKET 1.78 X 1.88 X .25
8	281951	1	DIVERTER BOTTOM GASKET
9	450221	1	Q.C. COUPLING (FEMALE)
10	450223	1	FITTING BRASS 1/8 FPT - 1/8 BARB
11	710353	1	SCR-MC 10-32 X .37 ST PL
12	711202	4	BLT-HH 1/4-20 X 0.50 STPL
13	711503	1	WSR, FLAT#10
14	711505	4	WSR-FLAT 1/4
15	711515	2	WSR-FLAT .406 X .812 X .0625
16	711543	1	WSR - HELICAL #10
17	711544	4	WSR-HELICAL 1/4
18	760247	1	O RING .312ID X .442 X .065

**BATTERY BOX ASSEMBLY**

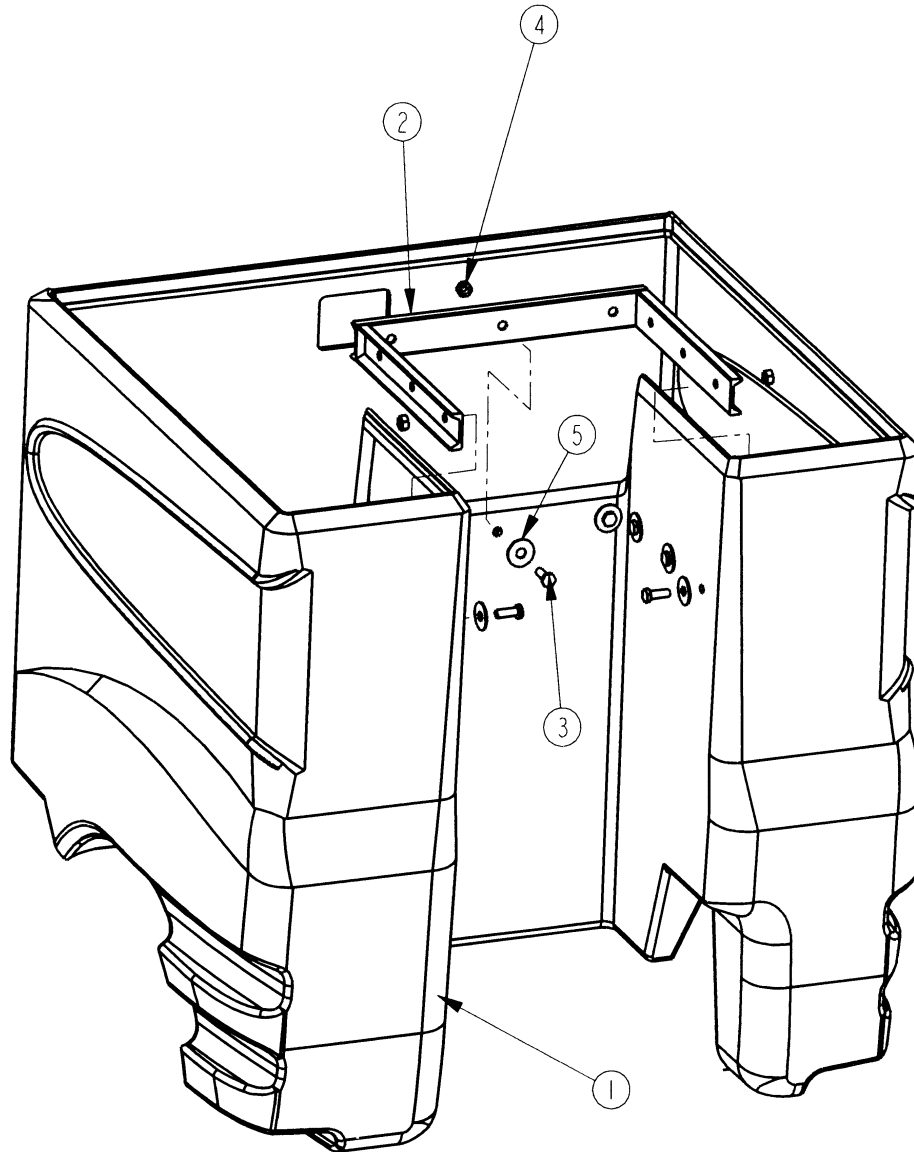

<b>BILL OF MATERIAL 281014</b>			
<b>ITEM</b>	<b>PART NO.</b>	<b>REQ'D</b>	<b>DESCRIPTION</b>
1	281004	1	BATTERY TRAY - 2800
2	281059	1	BATTERY BOX STIFFENER WM'T
3	711229	9	BLT-HH 5/16 -18 - .875
4	711374	9	NUT-NLOC 5/16-18
5	711507	9	WSR-FLAT .37 X 1.12 X .06

# PUMP ASSEMBLY

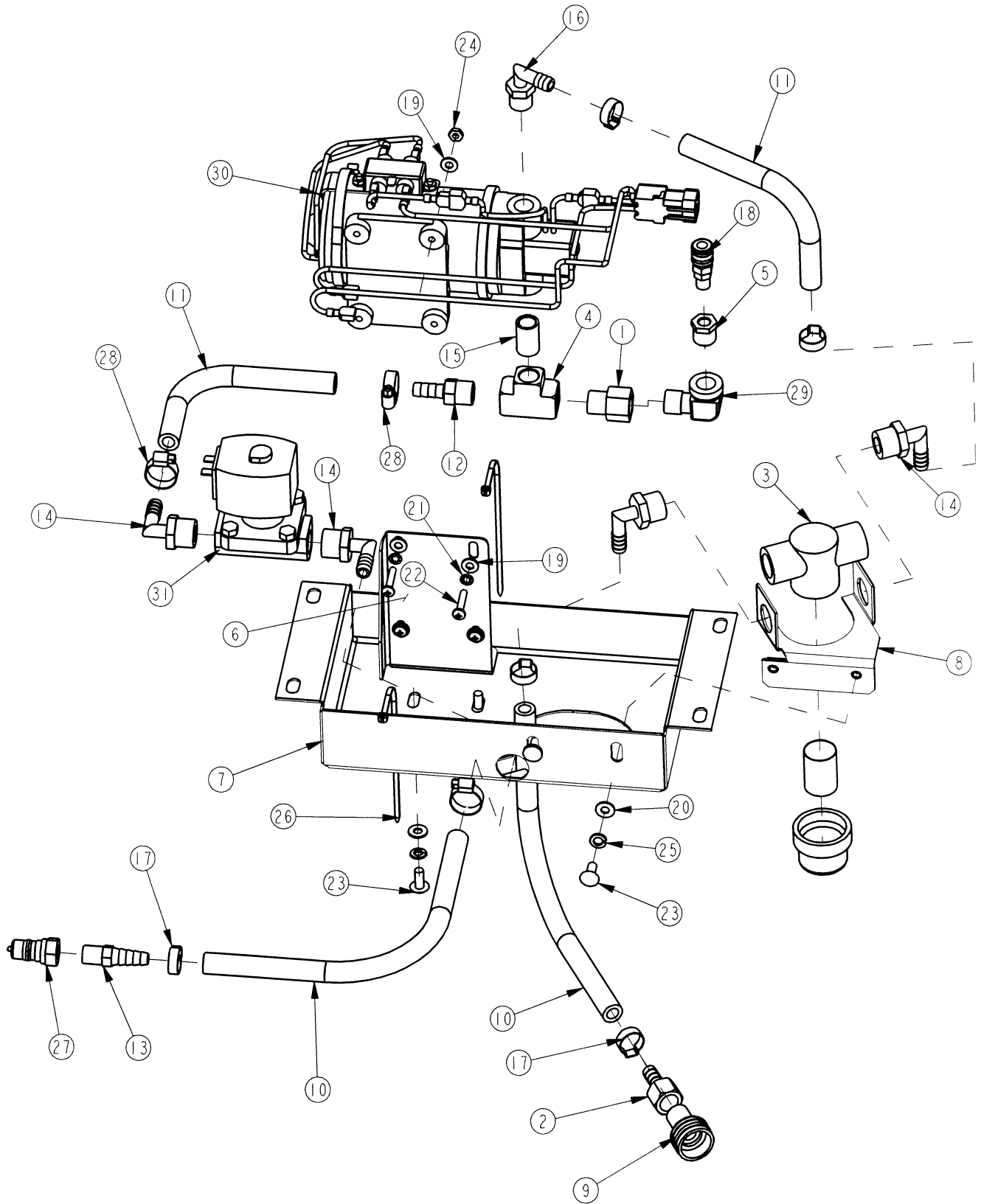

<b>BILL OF MATERIAL 281098</b>			
<b>ITEM</b>	<b>PART NO.</b>	<b>REQ'D</b>	<b>DESCRIPTION</b>
1	210409	1	FITTING ADAPTOR 3/8MPTx38/FPT BR
2	210410	1	FITTING BRASS 3/8" FPT X 3/8" BARB
3	281089	1	FILTER, IN-LINE
4	281090	1	FITTING BRASS 3/8" FPT TEE
5	281091	1	FITTING 3/8MPTx1/8 FPT REDUCER
6	281368	1	PUMP MOUNT PLATE
7	281369	1	PUMP SUPPORT PLATE
8	281388	1	PUMP MTG PLATE
9	281425	1	SWIVEL CONNECTOR - 3/4" GHT X 3/8" MPT
10	320251	2	HOSE 3/8 x 12 WIRE REINFORCED
11	320254	2	HOSE 3/8 x 9.00" WIRE REINFORCED
12	342430	1	FITTING BRASS 3/8BARB 3/8 HOSE
13	342435	1	FITTING 1/4MPTx3/8HB BRASS
14	383327	4	ELBOW 1/2 MPT X 3/8 BARB
15	383332	1	FITTING BRASS 3/8 NIPPLE
16	450040	1	FITTING 90 3/8 MPT X 3/8 BARB
17	450076	5	CRIMP CLAMP SS 185R
18	450221	1	Q.C. COUPLING (FEMALE)
19	711503	8	WSR, FLAT#10
20	711504	4	WSR-FLAT 1/4 ID SS
21	711553	4	WSR- INTERNAL LOCK #10
22	712531	4	SCR-MC 10-24 X 1.00 SS
23	712565	4	SCR-MC 1/4-20X.63 SS TR HD
24	712638	4	NUT, HEX 10-24 SS NYLOC
25	712758	4	WSR-HELICAL 1/4 SS
26	828062	2	CABLE TIE .05 x .14 x 8"
27	828368	1	MALE COUPLER
28	829129	3	HOSE CLAMP MICRO-SEAL
29	830062	1	FITTING 90 STREET ELBOW 3/8x3/8
30	742709-2	1	PUMP ASSEMBLY-SCV
31	742718-1	1	SOLENOID VALVE 36V

# REAR AXLE ASSEMBLY

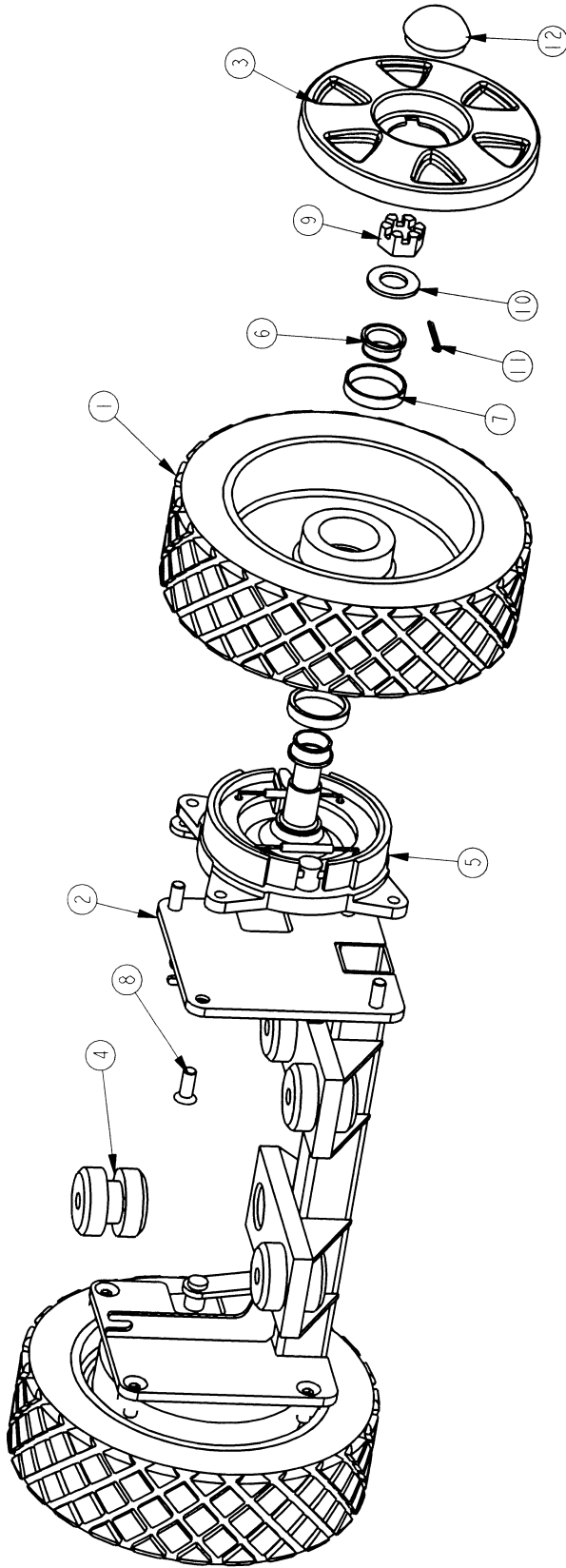

BILL OF MATERIAL 281201			
ITEM	PART NO.	REQ'D	DESCRIPTION
1	281031	2	REAR WHEEL 13.75 OD SOFT RIDE
2	281202	1	REAR AXLE WMT
3	281212	2	HUB CAP
4	281213	4	RING & BUSHING ISOLATOR
5	281443	2	DRUM BRAKE
6	383194	4	BEARING CONE
7	383195	4	BEARING CUP
8	711169	8	SCR-1/2-20 X 1.25 SOCKET FH W/ PATCH
9	711450	2	NUT-SLOTTED, 1-14 UNS
10	711514	2	WSR-FT 1.0 ID X 2.0 OD
11	380-632-20	2	3/16 COTTER PIN
12	383241PTD	2	GREASE CAP WHEEL-PAINTED

## SQUEEGEE MECHANISM ASSEMBLY

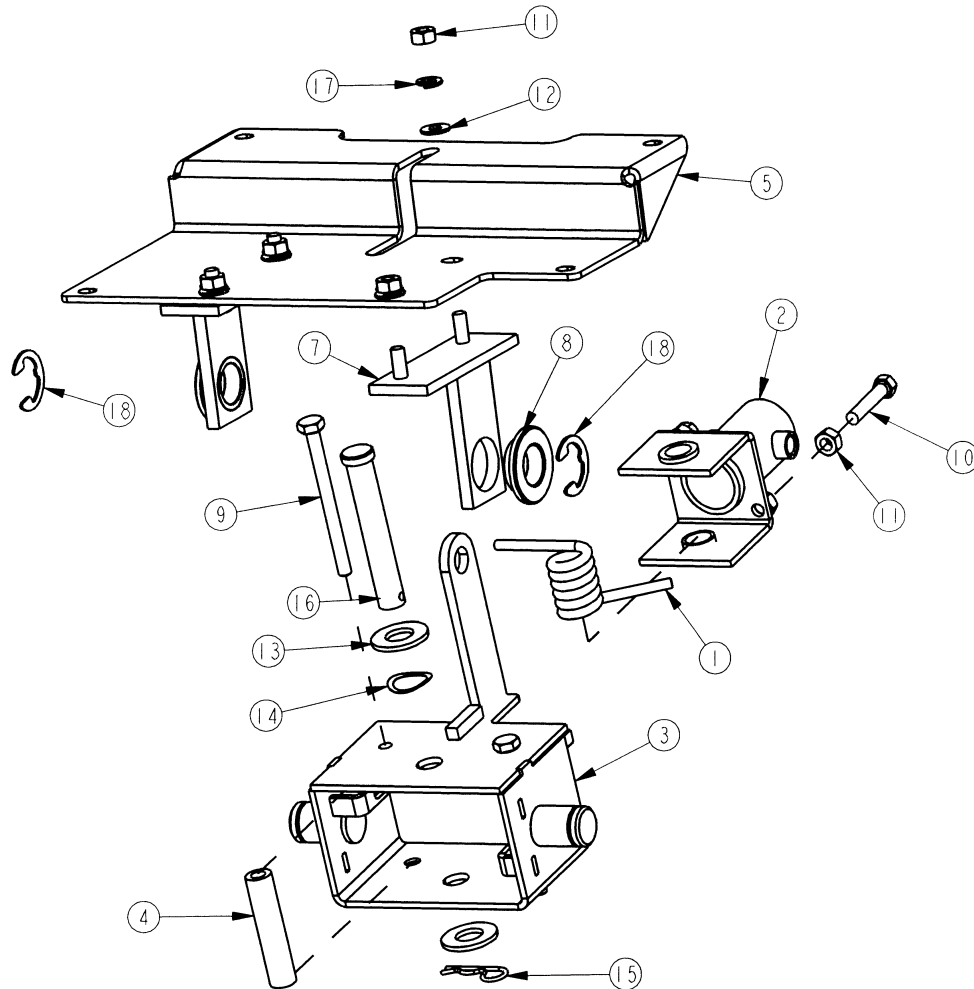

BILL OF MATERIAL 281702			
ITEM	PART NO.	REQ'D	DESCRIPTION
1	281064	1	TORSION SPRING
2	281703	1	SQUEEGEE YOKE SUBASSEMBLY
3	281706	1	SQ YOKE BRKT WMENT SUB-ASSY
4	281715	2	MECHANISM STOP TUBE
5	281717	1	SQUEEGEE MECHANISM ATTACHMENT PLATE
6	281720	2	SQUEEGEE MECHANISM ATTACHM'T WMT
7	281730	2	SQUEEGEE MECHANISM ATTACHM'T BRKT ASSY
8	320209	2	OILITE FLANGED BEARING
9	710593	2	SCR-MC 1/4-20X3.00 ST PL HH
10	711210	2	BLT-HH 1/4-20 X 1.25 STPL
11	711316	6	NUT-HEX 1/4-20 ST PL
12	711504	4	WSR-FLAT 1/4 ID SS
13	711509	2	WSR-FLAT 1/2 (.54X1.082X.087)
14	711525	1	WSR WAVE .65 x .86 x .01
15	711808	1	COTTER PIN-HAIR #13
16	712134	1	CLEVIS PIN, 1/2 x 3.00
17	712758	4	WSR-HELICAL 1/4 SS
18	809148	2	RETAINING RING - "E" TYPE EXT .75

# REAR SQUEEGEE ASSEMBLY 28"

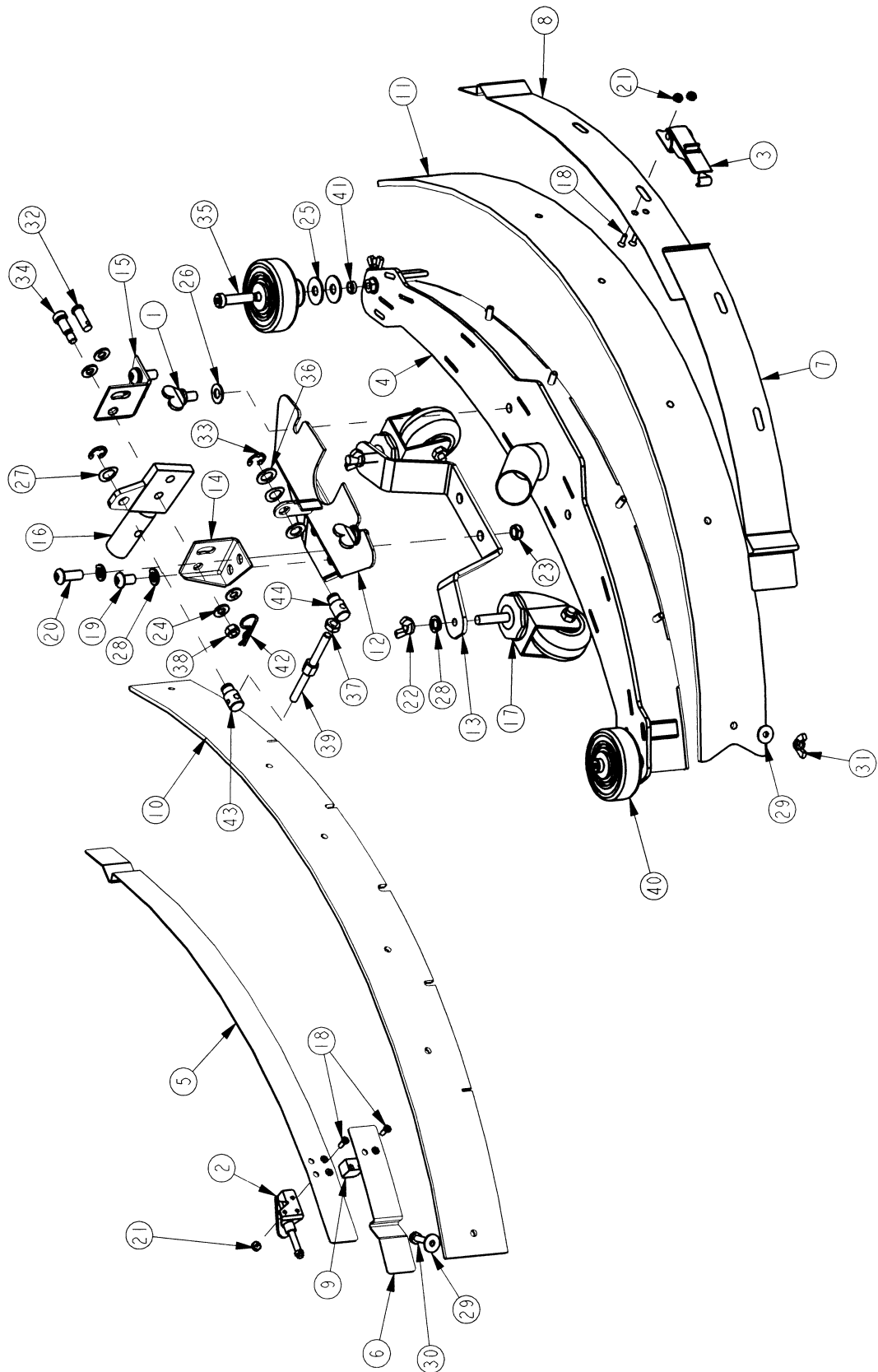



<i>BILL OF MATERIAL 281701</i>			
<i>ITEM</i>	<i>PART NO.</i>	<i>REQ'D</i>	<i>DESCRIPTION</i>
1	260267	2	WING BOLT 3/8-16 X .62 ST PL
2	281074	1	SQUEEGEE TOGGLE CLAMP, 2800
3	281075	1	SQUEEGEE LATCH, 2800
4	281721	1	SQUEEGEE WMT ASS'Y, 2800
5	281732	1	STRAP - FRONT CLAMP
6	281734	1	STRAP - FRONT STOP
7	281736	1	STRAP - REAR CATCH
8	281738	1	STRAP - REAR LATCH
9	281740	1	STOP BAR
10	281741	1	FRONT BLADE, SQUEEGEE GUM RUBBER
11	281742	1	REAR BLADE, SQUEEGEE GUM RUBBER
12	281745	1	SQUEEGEE MOUNT BRACKET WMT
13	281749	1	CASTER SUPPORT BRACKET
14	281755	1	SQUEEGEE ROD MOUNT BRACKET LEFT
15	281756	1	SQUEEGEE ROD MOUNT BRACKET RIGHT
16	281757	1	SQUEEGEE ROD MOUNT SUB-ASSEMBLY
17	430325	2	CASTER WHEEL 3/8"-16 X 1.500
18	710530	7	SCR-MC 8-32 X .50 BR
19	710985	2	SCR-SC 3/8-16 X .62 ST PL
20	710986	2	SCR-SC 3/8-16 X .87 ST PL
21	711026	5	NUT, HEX 8-32 NYLOC SS
22	711367	2	NUT- WING 3/8-16 ST PL
23	711375	2	NUT-NYLOC 3/8-16 X 1/2 NUT
24	711506	4	WSR-FLT .344 X .690 X .062 STL ZINC
25	711507	6	WSR-FLAT .37 X 1.12 X .06
26	711515	2	WSR-FLAT .406 X .812 X .0625
27	711524	2	WSR-WAVE .52 X .87 X .01
28	711546	6	WSR-HELICAL 3/8
29	711550	4	WSR NYLON .25 ID X .75 OD
30	711560	2	SCREW-HH 1/4-20X1.00 NYLON
31	711563	2	NUT- WING 1/4-20 NYLON
32	711668	1	CLEVIS PIN, 3/8X1 11-141
33	711713	2	RETAINING RING - "E" TYPE EXT .500
34	712081	1	SHOULDER BLT 3/8 X .75
35	712091	2	SHOULDER BLT 3/8 X 1.50
36	712310	2	WSR- FLAT .52 X .87 X .06 PL
37	712680	1	NUT-HEX 5/16-18 SS
38	712683	1	NUT, HEX 5/16-18 NYLOC SS
39	750689	1	ADJUSTMENT STUD
40	808829	2	WHEEL,TRUCK
41	832015	2	SPACER .38 X .50 X .140
42	833374	1	HAIRPIN COTTER 3/8
43	762256PLT	1	NUT, ADJUSTING (LH)
44	762257PLT	1	NUT, ADJUSTING (RH)

# REAR SQUEEGEE ASSEMBLY 32"

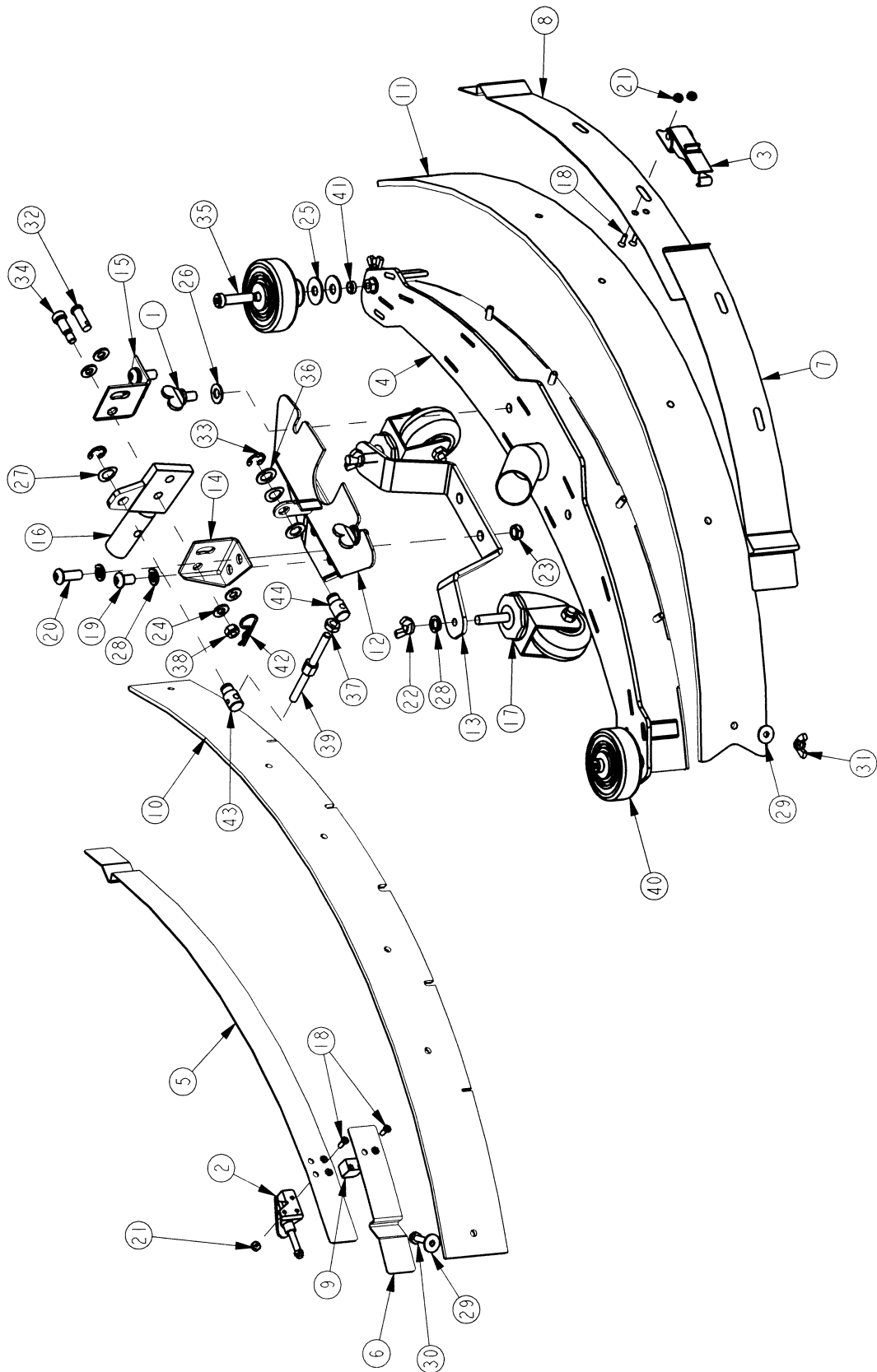

BILL OF MATERIAL 281775-1			
ITEM	PART NO.	REQ'D	DESCRIPTION
1	260267	2	WING BOLT 3/8-16 X .62
2	281074	1	SQUEEGEE TOGGLE CLAMP, 2800
3	281075	1	SQUEEGEE LATCH, 2800
4	281776	1	SQUEEGEE WMT ASSY, 2800 32"
5	281781	1	STRAP, FRONT CLAMP 32"
6	281782	1	STRAP FRONT STOP 32"
7	281783	1	STRAP REAR CATCH 32"
8	281784	1	STRAP REAR LATCH 32"
9	281740	1	STOP BAR
10	281785	1	FRONT BLADE SQUEEGEE GUM RUBBER 32"
11	281786	1	REAR BLADE SQUEEGEE GUM RUBBER 32"
12	281745	1	SQUEEGEE MOUNT BRACKET WMT
13	281749-1	1	PB CASTER SUPPORT BRKT
14	281755	1	SQUEEGEE ROD MOUNT BRACKET LEFT
15	281756	1	SQUEEGEE MOUNT BRACKET RIGHT
16	281757	1	SQUEEGEE ROD MOUNT SUB-ASSY
17	430325	2	CASTER WHEEL, 3/8-16 X 1.50
18	710530	7	SCR-MC 8-32 X .50 BR
19	710985	2	SCR-SC 3/8-16 X .62 ST PL
20	710986	2	SCR-SC 3/16 X .87 ST PL
21	711026	5	NUT HEX 8-32 NYLOC SS
22	711367	2	NUT WING 3/8-16 ST PL
23	711375	2	NUT NYLOC 3/8-16 X 1/2NUT
24	711506	4	WSR-FLT .344 X .690 X .062 STL ZINC
25	711507	6	WSR-FLAT .37 X 1.12 X .06
26	711515	2	WSR-FLAT .406 X .812 X .0625
27	711524	2	WSR-WAVE .52 X .87 X .01
28	711546	6	WSR-HELICAL 3/8
32	711668	1	CLEVIS PIN 3/8 X 1 11-141
33	711713	2	RETAINING RING- "E"TYPE EXT .500
34	712081	1	SHOULDER BOLT 3/8 X .75
35	712091	2	SHOULDER BOLT 3/8 X 1.50
36	712310	2	WSR-FLAT .52 X .87 X .06 PL
37	712680	1	NUT-HEX 5/16-18 SS
38	712683	2	NUT HEX 5/16-18 NYLOC SS
39	750689	1	ADJUSTMENT NUT
40	808829	2	WHEEL, TRUCK
41	832015	2	SPACER, .38 X .50 X .14
42	833374	1	HAIRPIN COTTER, 3/8
43	762256PLT	1	NUT ADJUSTING (LH)
44	762257PLT	1	NUT ADJUSTING (RH)

# 28" CYLINDRICAL SCRUB DECK ASSEMBLY

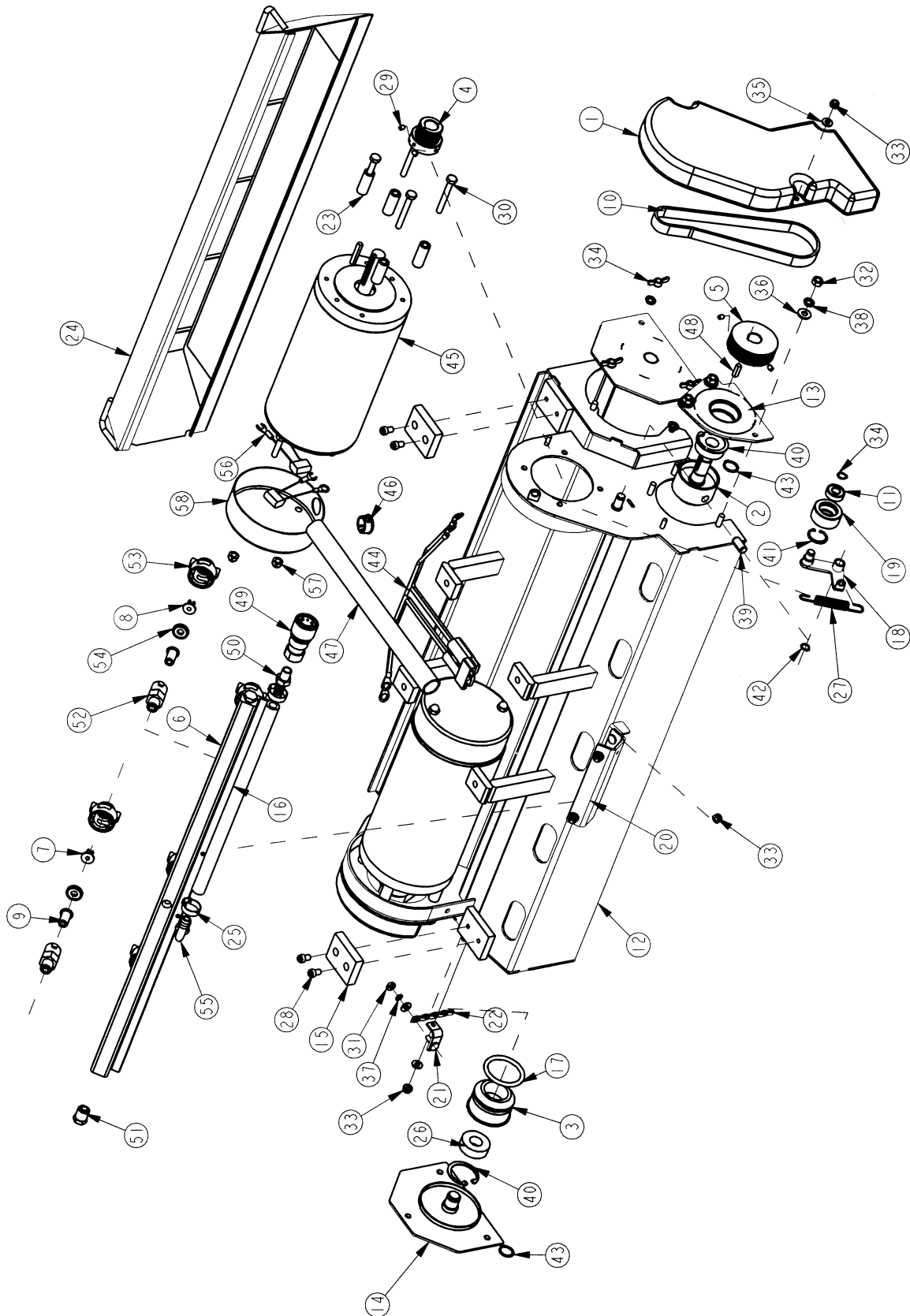

BILL OF MATERIAL 281501		
ITEM	PART NO.	REQ'D DESCRIPTION
1	281023	2 BELT COVER, CYLINDRICAL SCRUBDECK
2	281034	2 DRIVE HUB, CYLINDRICAL SCRUBDECK
3	281035	2 IDLE HUB, CYLINDRICAL SCRUBDECK
4	281036	2 OFFSET PULLEY POLY V
5	281037	2 DRIVEN PULLEY
6	281038	1 SPRAY BAR
7	281039	2 SPRAY TIP 6503
8	281040	3 SPRAY TIP 11005
9	281041	5 CHECK VALVE
10	281053	2 J BELT ( POLY V ) 18"
11	281058	2 BEARING 3/8" RADIAL
12	281502	1 CYLINDRICAL SCRUBDECK WELDMENT
13	281505	2 BRUSH DRIVE HUB WMT
14	281512	2 IDLE SHAFT WMT
15	281515	2 WEAR PLATE
16	281517	1 SOL FEED HOSE, 28" CYL DECK
17	281519	2 O-RING 1.62 X 2.00 X .188
18	281544	2 TENSIONER ARM WELDMT
19	281548	2 BELT IDLER
20	281549	1 BRKT, SPRAY BAR
21	281557	1 DRAG CHAIN BRKT, CYL. SCRUBDECK
22	281558	1 DRAG CHAIN, CYL. SCRUBDECK
23	281598	8 MOTOR STANDOFF - CYL SCRUB DECK
24	281901	1 DEBRIS BOX WMT, CYLINDRICAL SCRUBDECK
25	363347	2 CRIMP CLAMP 1/2 HOSE SS 185R
26	363582	4 BALL BEARING, RADIAL 5/8"
27	430051	2 RETURN SPRING-3.00"
28	710961	4 SCR-SC 1/4-20 X .37
29	711003	8 SCR-SK 10-32 x .25

BILL OF MATERIAL 281501		
ITEM	PART NO.	REQ'D DESCRIPTION
30	711214	8 BLT-HH 1/4-20 X 2.00
31	711310	1 NUT, HEX 10-32 ST PL
32	711316	8 NUT-HEX 1/4-20 ST PL
33	711350	10 NUT NYLOC 10-32
34	711389	6 NUT-WING 1/4-20 STL ZINC
35	711503	9 WSR, FLAT#10
36	711505	6 WSR-FLAT 1/4
37	711543	1 WSR - HELICAL #10
38	711544	12 WSR-HELICAL 1/4
39	711676	4 ROLL PIN, 3/8 x 3/4
40	711701	4 RETAINING RING, INT 1.37
41	711704	2 INTERNAL RETAINING RING N5000-86 .875 DIA.
42	711724	3 3/8" RETAINING RING, EXTERNAL
43	711725	4 5/8" RETAINING RING, EXTERNAL
44	748046	1 WIRE ASSY, BRUSH DECK CYLINDER
45	748048	2 MOTOR 1 HP, 36V, 1800RPM
46	748122	2 BUSHING, HEYCO 2103 I.D. .625.
47	748141	1 CABLE WRAP, 11"
48	760043	2 KEY, 3/16 X .675 L
49	828370	1 1/4 NPT SOCKET FEMALE END COUPLI
50	828952	1 FITTING PP 1/4" MPT X 3/8" HOSE BARB
51	829619	2 END PLUG
52	833140	5 BODY INLET CONNECTOR
53	833141	5 CAP
54	833142	5 GASKET CAP
55	833325	1 FITTING NYLON 90 1/4MPT X 3/8HB
56	744016-1	4 CAP .15 MICROFARAD 5/16R-1/4FORK
57	711352	4 NUT ACORN 1/4-20 ST
58	748048-2	2 COVER, MOTOR TERMINAL REPLACEMENT

# 28" DISC SCRUB DECK ASSEMBLY

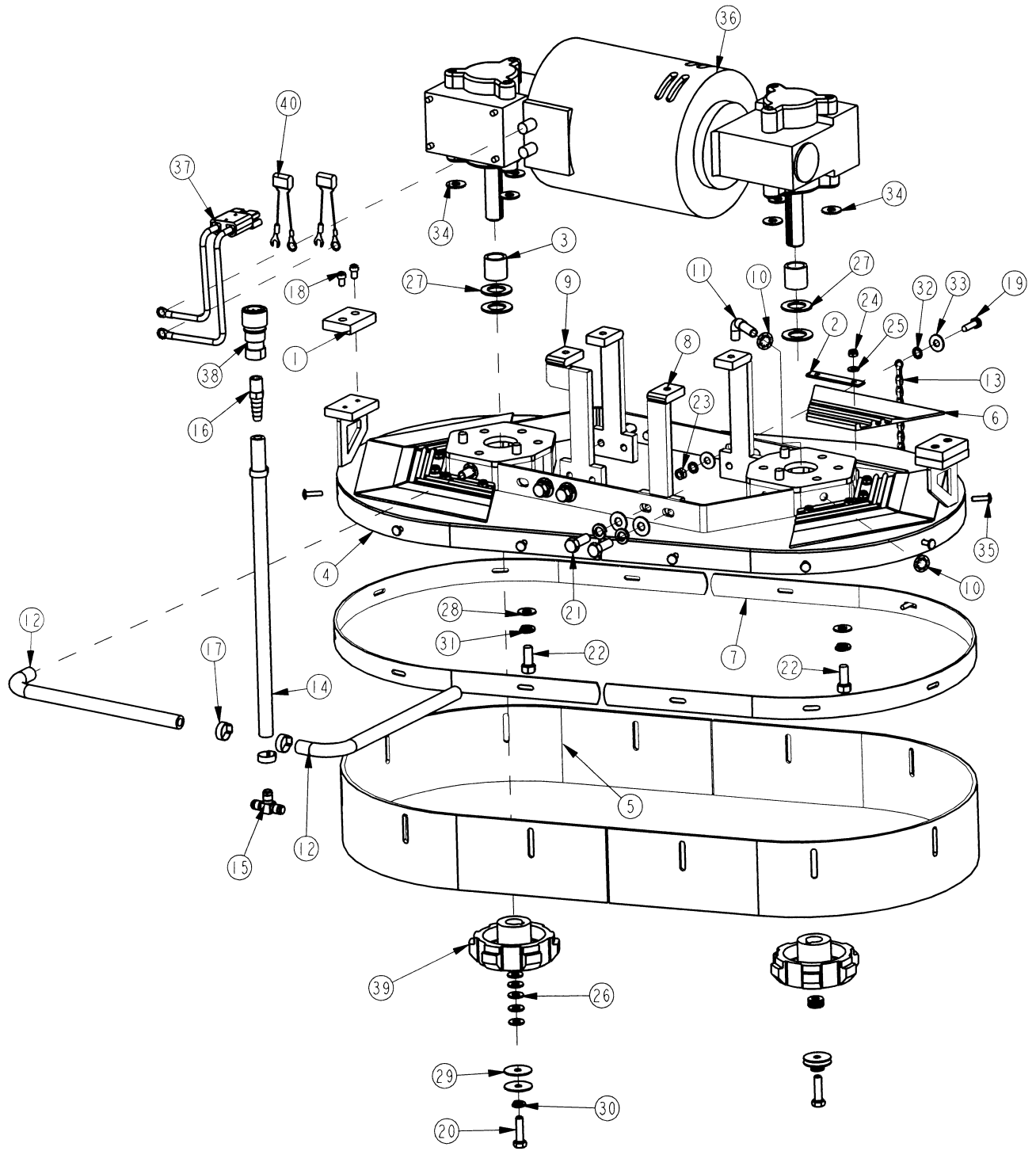

<i>BILL OF MATERIAL 281601</i>			
<i>ITEM</i>	<i>PART NO.</i>	<i>REQ'D</i>	<i>DESCRIPTION</i>
1	281515	2	WEAR PLATE
2	281610	6	STRAP, KEEPER
3	281611	2	HUB-SCRUB SPACER TUBE
4	281612	1	DISK SCRUBDECK WMT, 28"
5	281613	2	SKIRT, 28" DISK
6	281614	6	FLAP, DISK
7	281615	2	STRAP, DISK
8	281616	3	DISK MTG BRKT WMT
9	281617	1	DISK OFFSET MTG BRKT WMT
10	281633	4	SPEED NUT - 3/8"
11	281634	2	DISK SOLUTION FEED ASSY
12	281637	2	SOL. FEED END HOSE
13	281644	1	DRAG CHAIN ASSY, DISK SCRUBDECK
14	320253	1	HOSE, SOLUTION VALVE 14"
15	320266	1	FITTING BRASS TEE DBL 3/8 BARB
16	342435	1	FITTING 1/4MPTx3/8HB BRASS
17	450076	4	CRIMP CLAMP SS 185R
18	710961	4	SCR-SC 1/4-20 X .37
19	711206	1	BLT-HH 1/4-20 X .87 ST PL
20	711231	2	BLT-HH 5/16-18X1.25 ST PL
21	711242	8	BLT-HEX 3/8 -16X1.00 ZP
22	711246	6	BLT-HH 3/8-16 X .87 ST PL
23	711316	1	NUT-HEX 1/4-20 ST PL
24	711350	12	NUT NYLOC 10-32
25	711503	12	WSR, FLAT#10
26	711506	10	WSR-FLT .344 X .690 X .062 STL ZINC
27	711512	4	WSR-FLAT .75X1.37X.08
28	711515	6	WSR-FLAT .406 X .812 X .0625
29	711516	4	WSR- FLAT .31 X 1.25 X .05
30	711545	2	WSR-HELICAL 5/16
31	711546	14	WSR-HELICAL 3/8
32	711554	2	WSR-INTERNAL LOCK 1/4 ID
33	711575	2	WSR-FLT .31x.75x.06ST
34	712301	14	WSR-FLAT .87 X .38 X .06
35	712537	12	10-24 X .75 SS TRUSS HD SCR
36	748003	1	DUAL RIGHT ANGLE DRIVE, 28"
37	748077	1	WIRE ASSY, BRUSH DECK DISK
38	828370	1	1/4 NPT SOCKET FEMALE END COUPLI
39	3312402	2	HUB-SCRUB BRUSH DRIVE
40	744016-1	2	CAP .15 MICROFARAD 5/16R-1/4FORK

# 32" CYLINDRICAL SCRUB DECK ASSEMBLY

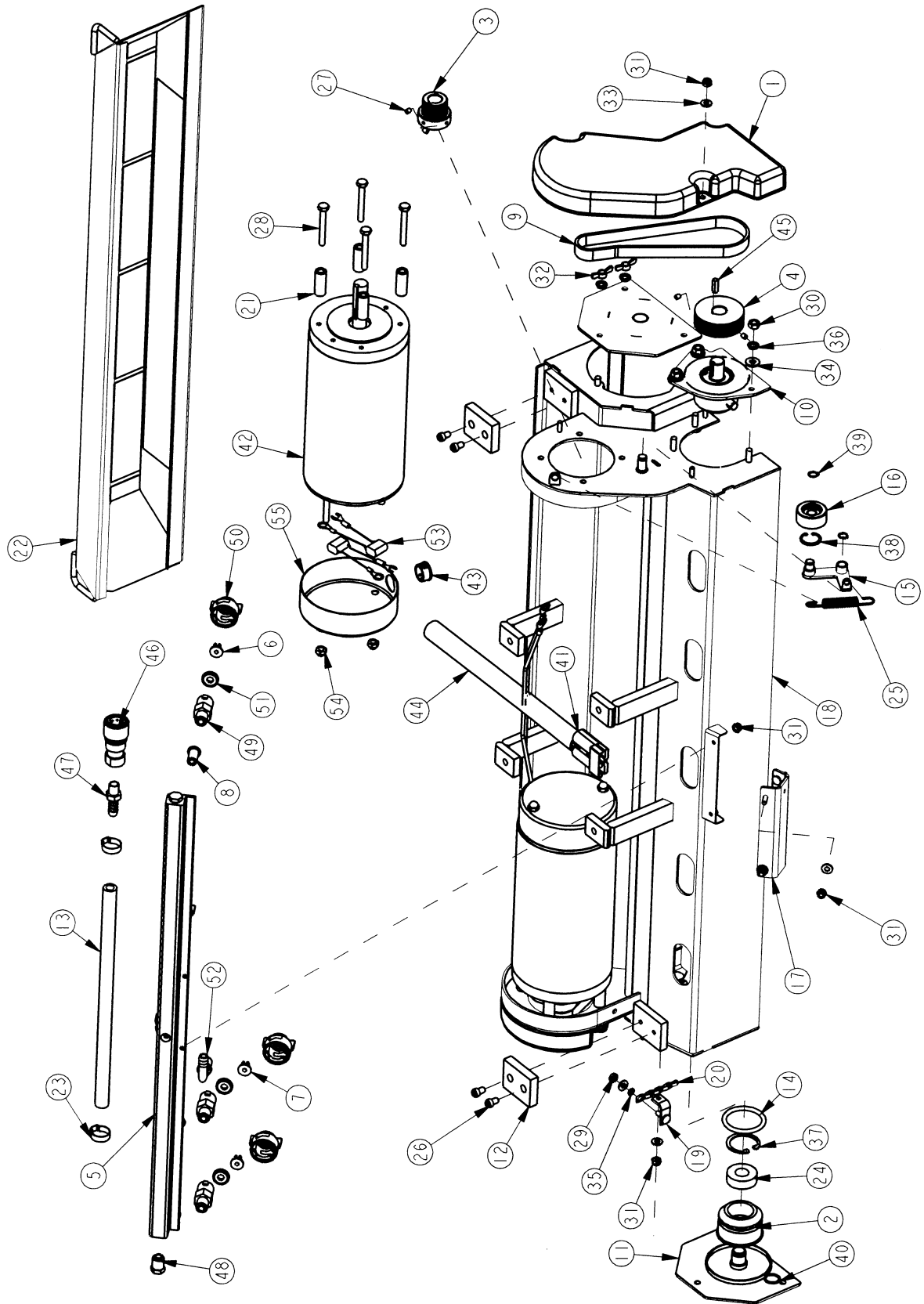



BILL OF MATERIAL 281551			
ITEM	PART NO.	REQ'D	DESCRIPTION
1	281023	2	BELT COVER, CYLINDRICAL SCRUBDECK
2	281035	2	IDLE HUB, CYLINDRICAL SCRUBDECK
3	281036	2	OFFSET PULLEY POLY V
4	281037	2	DRIVEN PULLEY
5	281038	1	SPRAY BAR
6	281039	2	SPRAY TIP 6503
7	281040	3	SPRAY TIP 11005
8	281041	5	CHECK VALVE
9	281053	2	J BELT ( POLY V ) .18"
10	281503	2	BRUSH DRIVE HUB ASSY
11	281512	2	IDLE SHAFT WMT
12	281515	2	WEAR PLATE
13	281517	1	SOL FEED HOSE, 28" CYL DECK
14	281519	2	O-RING 1.82 X 2.00 X .188
15	281544	2	TENSIONER ARM WELDMT
16	281547	2	IDLER SUB ASSY
17	281549	1	BRKT, SPRAY BAR
18	281552	1	CYLINDRICAL SCRUBDECK WELDMNT, 32"
19	281557	1	DRAG CHAIN BRKT, CYL. SCRUBDECK
20	281558	1	DRAG CHAIN, CYL. SCRUBDECK
21	281598	8	MOTOR STANDOFF - CYL SCRUB DECK
22	281906	1	DEBRIS BOX WMT, CYLINDRICAL SCRUBDECK 32"
23	383347	2	CRIMP CLAMP 1/2 HOSE SS 18SR
24	383582	2	BALL BEARING, RADIAL 5/8"
25	430051	2	RETURN SPRING-3.00"
26	710961	4	SCR-SC 1/4-20 X .37
27	711003	8	SCR-SK 10-32 x .25
28	711214	8	BLT-HH 1/4-20 X 2.00

BILL OF MATERIAL 281551			
ITEM	PART NO.	REQ'D	DESCRIPTION
29	711310	1	NUT, HEX 10-32 ST PL
30	711316	8	NUT-HEX 1/4-20 ST PL
31	711350	10	NUT NYLOC 10-32
32	711389	6	NUT-WING 1/4-20 STL ZINC
33	711503	9	WSR, FLAT#10
34	711505	6	WSR-FLAT 1/4
35	711543	1	WSR - HELICAL #10
36	711544	12	WSR-HELICAL 1/4
37	711701	2	RETAINING RING, INT 1.37
38	711704	2	INTERNAL RETAINING RING N5000-86 .875 DIA.
39	711724	3	3/8" RETAINING RING, EXTERNAL
40	711725	2	5/8" RETAINING RING, EXTERNAL
41	748046	1	WIRE ASSY, BRUSH DECK CYLINDER
42	748048	2	MOTOR 1 HP, 36V, 1800RPM
43	748122	2	BUSHING, HEYCO 2103 I.D .625.
44	748141	1	CABLE WRAP, 11"
45	760043	2	KEY, 3/16 X .675 L
46	828370	1	1/4 NPT SOCKET FEMALE END COUPLI
47	828852	1	FITTING PP 1/4" MPT X 3/8" HOSE BARB
48	829619	2	END PLUG
49	833140	5	BODY INLET CONNECTOR
50	833141	5	CAP
51	833142	5	GASKET CAP
52	833325	1	FITTING NYLON 90 1/4MPT X 3/8HB
53	744016-1	4	CAP .15 MICROFARAD 5/16R-1/4FORK
54	711352	4	NUT ACORN 1/4-20
55	748048-2	2	MOTOR TERMINALS COVER- REPLACEMENT

# 32" DISC SCRUB DECK ASSEMBLY

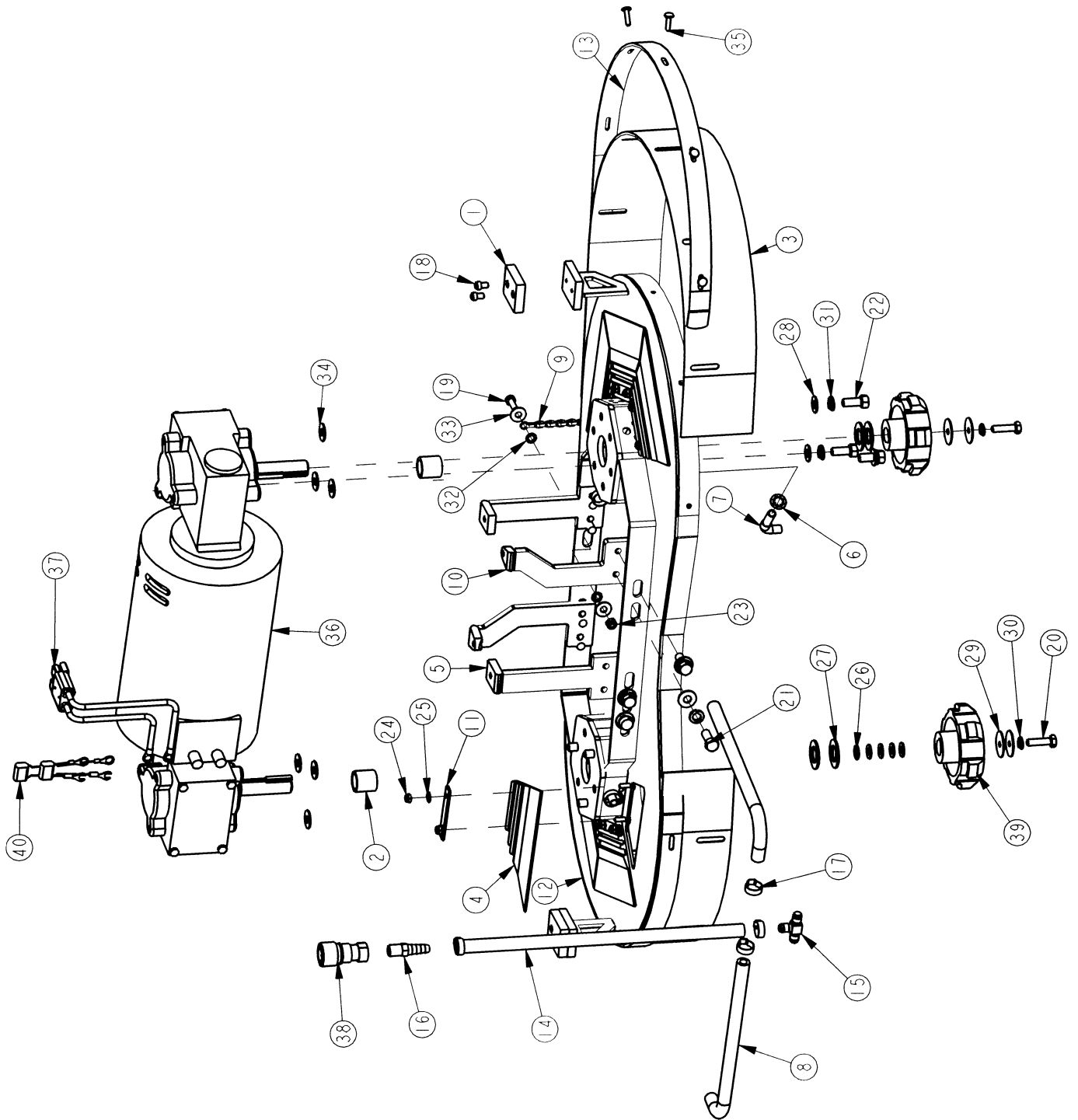

<i>BILL OF MATERIAL 281651</i>			
<i>ITEM</i>	<i>PART NO.</i>	<i>REQ'D</i>	<i>DESCRIPTION</i>
1	281515	2	WEAR PLATE
2	281611	2	HUB-SCRUB SPACER TUBE
3	281613	2	SKIRT, 28" DISK
4	281614	6	FLAP, DISK
5	281616	2	DISK MTG BRKT WMT
6	281633	2	SPEED NUT - 3/8"
7	281634	2	DISK SOLUTION FEED ASSY
8	281642	2	SOL. FEED END HOSE
9	281644	1	DRAG CHAIN ASSY, DISK SCRUBDECK
10	281657	2	DISK MTG BRKT WMT
11	281660	6	STRAP, KEEPER
12	281662	1	DISK SCRUBDECK WMT, 32"
13	281665	2	STRAP, DISK
14	320253	1	HOSE, SOLUTION VALVE 14"
15	320266	1	FITTING BRASS TEE DBL 3/8 BARB
16	342435	1	FITTING 1/4MPTx3/8HB BRASS
17	450076	6	CRIMP CLAMP SS 185R
18	710961	4	SCR-SC 1/4-20 X .37
19	711206	1	BLT-HH 1/4-20 X .87 ST PL
20	711231	2	BLT-HH 5/16-18X1.25 ST PL
21	711242	8	BLT-HEX 3/8 -16X1.00 ZP
22	711246	6	BLT-HH 3/8-16 X .87 ST PL
23	711316	1	NUT-HEX 1/4-20 ST PL
24	711350	12	NUT NYLOC 10-32
25	711503	12	WSR, FLAT#10
26	711506	10	WSR-FLT .344 X .690 X .062 STL ZINC
27	711512	4	WSR-FLAT .75X1.37X.08
28	711515	6	WSR-FLAT .406 X .812 X .0625
29	711516	4	WSR- FLAT .31 X 1.25 X .05
30	711545	2	WSR-HELICAL 5/16
31	711546	14	WSR-HELICAL 3/8
32	711554	2	WSR-INTERNAL LOCK 1/4 ID
33	711575	2	WSR-FLT .31x.75x..06ST
34	712301	14	WSR-FLAT .87 X .38 X .06
35	712537	12	10-24 X .75 SS TRUSS HD SCR
36	748033	1	MOTOR, 32" DUAL RIGHT ANGLE
37	748077	1	WIRE ASSY, BRUSH DECK DISK
38	828370	1	1/4 NPT SOCKET FEMALE END COUPLI
39	3312402	2	HUB-SCRUB BRUSH DRIVE
40	744016-1	2	CAP .15 MICROFARAD 5/16R-1/4FORK

# CYLINDRICAL DECK AND SIDE SQUEEGEE MOUNTING

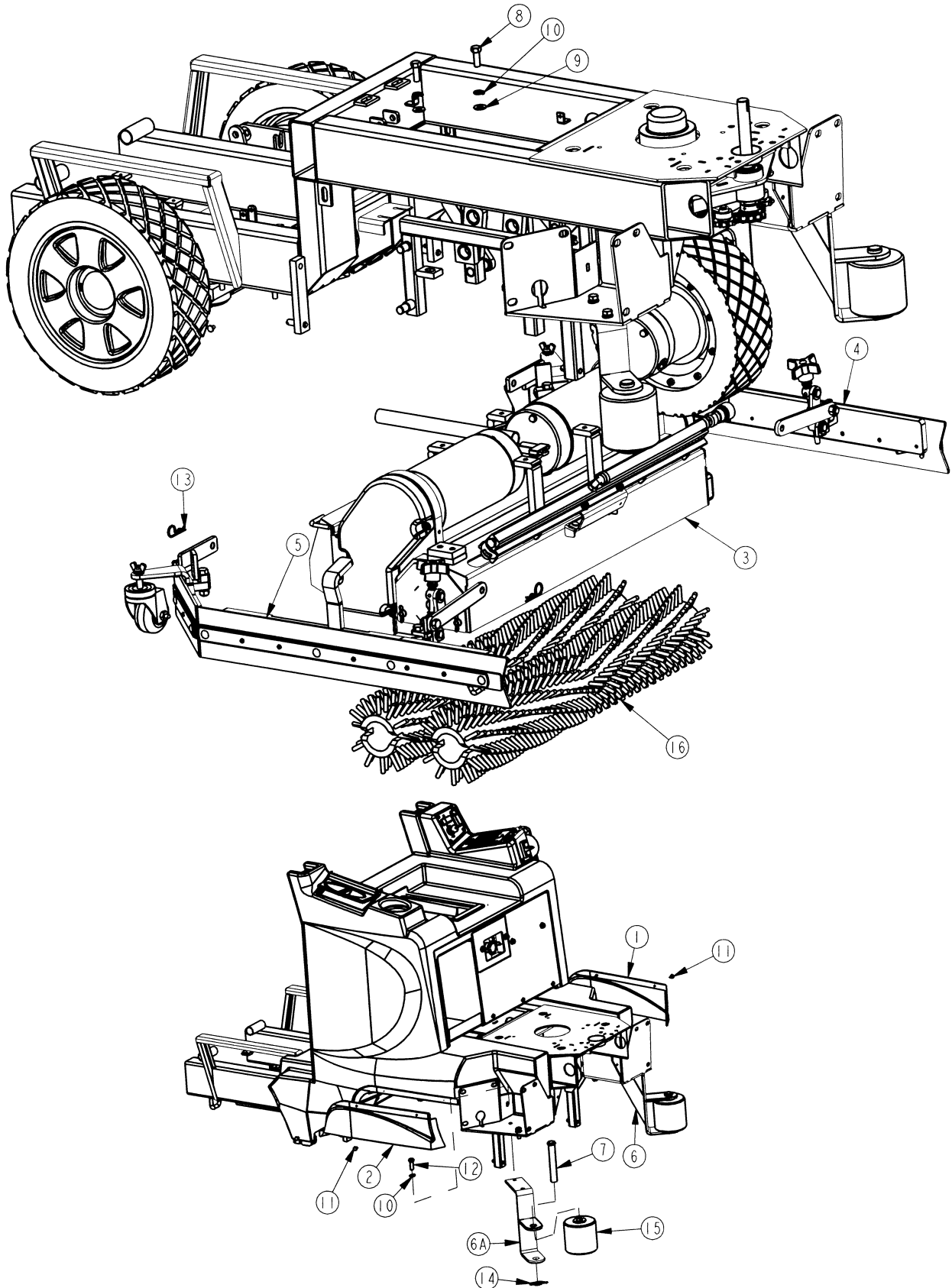

<i>BILL OF MATERIAL SC280000QP</i>			
<i>ITEM</i>	<i>PART NO.</i>	<i>REQ'D</i>	<i>DESCRIPTION</i>
1	281021	1	BRUSH DECK COVER 2800 - LH
2	281022	1	BRUSH DECK COVER 2800 - RH
3	281501	1	CYLINDRICAL SCRUBDECK ASSY, 28" NO BRUSHES
4	281911	1	SIDE SQUEEGEE ASSY, SCV LH
5	281912	1	SIDE SQUEEGEE ASSY, SCV RH
6	281955	2	FRONT ROLLER MOUNT BRKT WMT
7	360017	2	3/4" X 4.50 CLEVIS PIN
8	711242	4	BLT-HEX 3/8 - 16X1.00 ZP
9	711515	4	WSR-FLAT .406 X .812 X .0625
10	711546	8	WSR-HELICAL 3/8
11	712540	4	SCR-MC 10-24 X .37 SS TH
12	713042	4	BLT-HH 3/8-16 X 1 #5
13	833374	4	HAIRPIN COTTER 3/8
14	3400661	2	PIN-COTTER 5/8 RUE-RING
15	66-436-A	2	RUBBER ROLLER
16	281520	2	BRUSH, CYL 28" .022 NYLON
16A	281521	2	BRUSH, CYL 28" .028 BRISTLE
16B	281522	2	BRUSH 28", POLYPROPYLENE .022
16C	281525	2	BRUSH 28", POWER SCRUB 120 GRIT
16D	281526	2	BRUSH 28", NYLOGRIT 80 GRIT
16E	281527	2	BRUSH 28", STRATAGRIT 46 GRIT
16F	281529	2	BRUSH 28", SCRUBGRIT 180 GR

<i>BILL OF MATERIAL SC320000QP</i>			
<i>ITEM</i>	<i>PART NO.</i>	<i>REQ'D</i>	<i>DESCRIPTION</i>
1	281021-1	1	BRUSH DECK COVER 32" LH
2	281022-1	1	BRUSH DECK COVER 32" RH
3	281551	1	CYLINDRICAL SCRUBDECK ASSY 32: NO BRUSH
4	281961	1	SIDE SQUEEGEE ASSY 32" LH
5	281962	1	SIDE SQUEEGEE ASSY 32" RH
6	281971	1	FRONT ROLLER BRKT WMT 32" LH
6A	281976	1	FRONT ROLLER BRKT WMT 32" RH
7	360017	2	3/4 X 4.50 CLEVIS PIN
8	711242	4	BLT-HH 3/8-16 X 1 ZP
9	711515	4	WSR FLAT .406 X .812 X .06
10	711546	8	WSR-HELICAL 3/8
11	712540	4	SCR-MC 10-24 X .37
12	713042	4	BLT-HH 3/8-16 X 1.00 #5
13	833374	4	HAIRPIN, COTTER 3/8
14	3400661	2	PIN COTTER 5/8 RUE RING
15	66-436-A	2	RUBBER ROLLER
16	281530	2	BRUSH 32" CYL, .022 NYLON
16A	281531	2	BRUSH 32" CYL, .028 BRISTLE
16B	281532	2	BRUSH 32" CYL, .022 POLYPROPYLENE
16C	281535	2	BRUSH 32" CYL, 120 GRIT POWER SCRUB
16D	281536	2	BRUSH 32" CYL, 80 GRIT NYLOGRIT
16E	281537	2	BRUSH 32" CYL, 46 GRIT STRATAGRIT
16F	281539	2	BRUSH 32" CYL, SCRUBGRIT 180 GR

# DISC SCRUBDECK AND SIDE SQUEEGEE MOUNTING

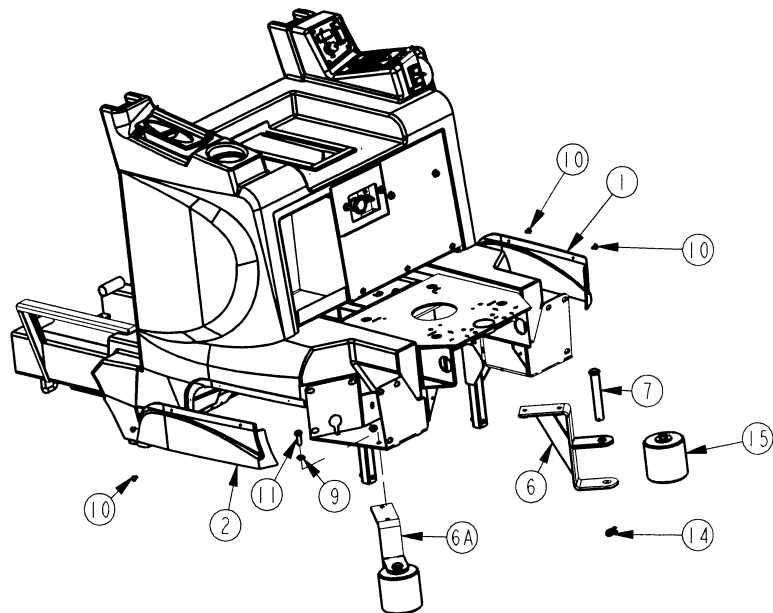
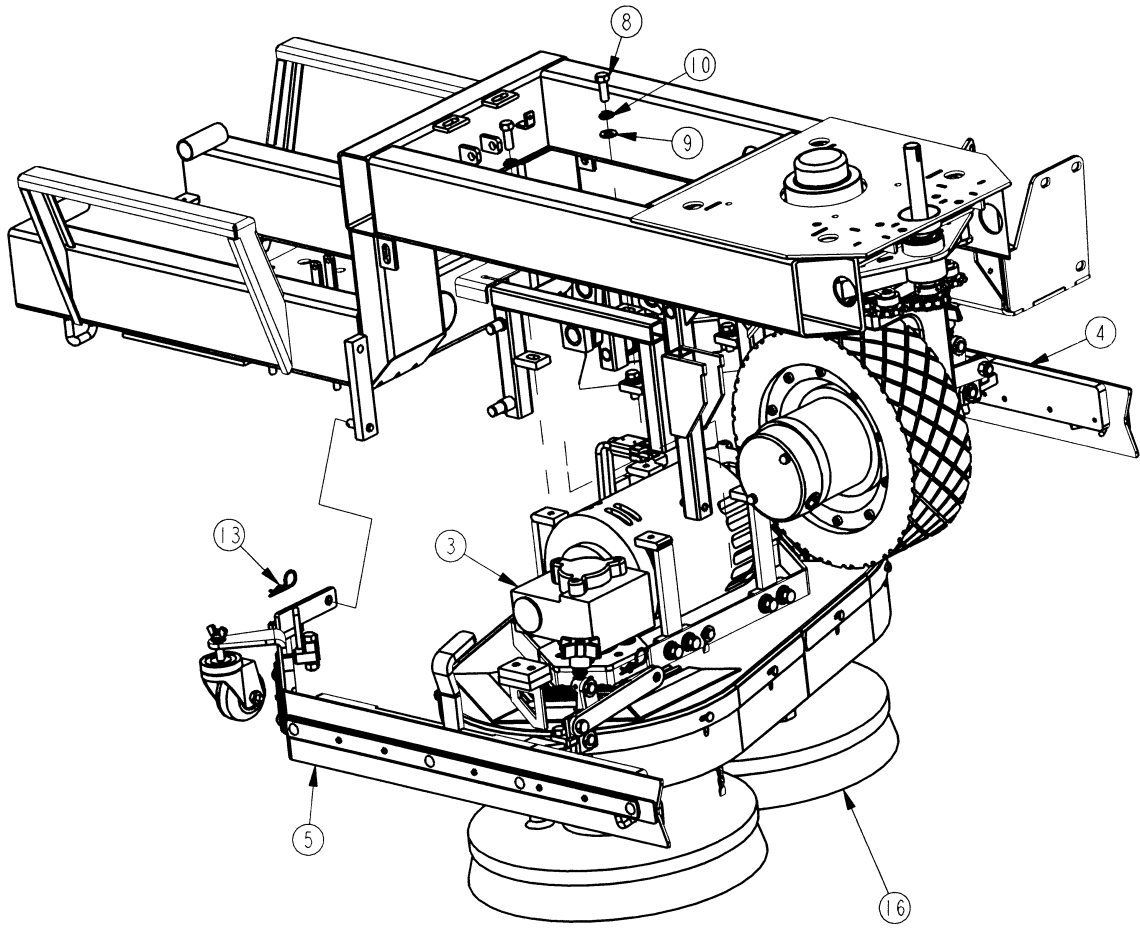

<i>BILL OF MATERIAL SC280001QP</i>			
<i>ITEM</i>	<i>PART NO.</i>	<i>REQ'D</i>	<i>DESCRIPTION</i>
1	281021	1	BRUSH DECK COVER 2800 - LH
2	281022	1	BRUSH DECK COVER 2800 - RH
3	281601	1	DISK SCRUBDECK ASSY 28" NO BRUSH
4	281911	1	SIDE SQUEEGEE ASSY, SCV LH
5	281912	1	SIDE SQUEEGEE ASSY, SCV RH
6	281955	2	FRONT ROLLER MOUNT BRKT WMT
7	360017	2	3/4" X 4.50 CLEVIS PIN
8	711242	4	BLT-HEX 3/8 -16X1.00 ZP
9	711515	4	WSR-FLAT .406 X .812 X .0625
10	711546	8	WSR-HELICAL 3/8
11	712540	4	SCR-MC 10-24 X .37 SS TH
12	713042	4	BLT-HH 3/8-16 X 1 #5
13	833374	4	HAIRPIN COTTER 3/8
14	3400661	2	PIN-COTTER 5/8 RUE-RING
15	66-436-A	2	RUBBER ROLLER
16	3313135	2	BRUSH 14", PLASTIC NYLON
16A	3313125	2	BRUSH 14", POWERGRIT 80
16B	3313127	2	BRUSH 14", POWERGRIT 46
16C	3313131	2	BRUSH 14", WIRE
16D	3313133	2	BRUSH 14", BUTCHER WIRE
16E	3315494	2	PAD DRIVER W/PAD HOLDER 14"
16F	3315386	2	BRUSH 14", POWERGRIT 120

<i>BILL OF MATERIAL SC320001QP</i>			
<i>ITEM</i>	<i>PART NO.</i>	<i>REQ'D</i>	<i>DESCRIPTION</i>
1	281021-1	1	BRUSH DECK COVER 32" LH
2	281022-1	1	BRUSH DECK COVER 32" RH
3	281651	1	DISK SCRUBDECK ASSY 32"
4	281961	1	SIDE SQUEEGEE ASSY LH 32"
5	281962	1	SIDE SQUEEGEE ASSY RH 32"
6	281971	1	FRONT ROLLER MNT BRKT WMT 32" LH
6A	281976	1	FRONT ROLLER MNT BRKT WMT 32" RH
7	360017	2	3/4" X 4.50" CLEVIS PIN
8	711242	4	BLT-HH 3/8-16 X 1.00
9	711515	4	WSR-FLAT .406 X .812 X .0625
10	711546	8	WSR-HELICAL 3/8
11	712540	4	SCR MC 10-24 X .37
12	713042	2	BLT-HH 3/8-16 X 1.00 #5
13	833374	4	HAIRPIN COTTER 3/8
14	3400661	2	PIN COTTER 5/8 RUE RING
15	66-436-A	2	RUBBER ROLLER
16	3313136	2	BRUSH SCRUB 16" PLASTIC NYLON
16A	3313126	2	BRUSH 16", POWERGRIT 80
16B	3313128	2	BRUSH 16", POWERGRIT 46
16C	3313132	2	BRUSH 16", WIRE
16D	3315385	2	BRUSH 16", POWERGRIT 120
16E	3315495	2	PAD DRIVER W/PAD HOLDER

**28" SIDE SQUEEGEE (RIGHT SIDE)**

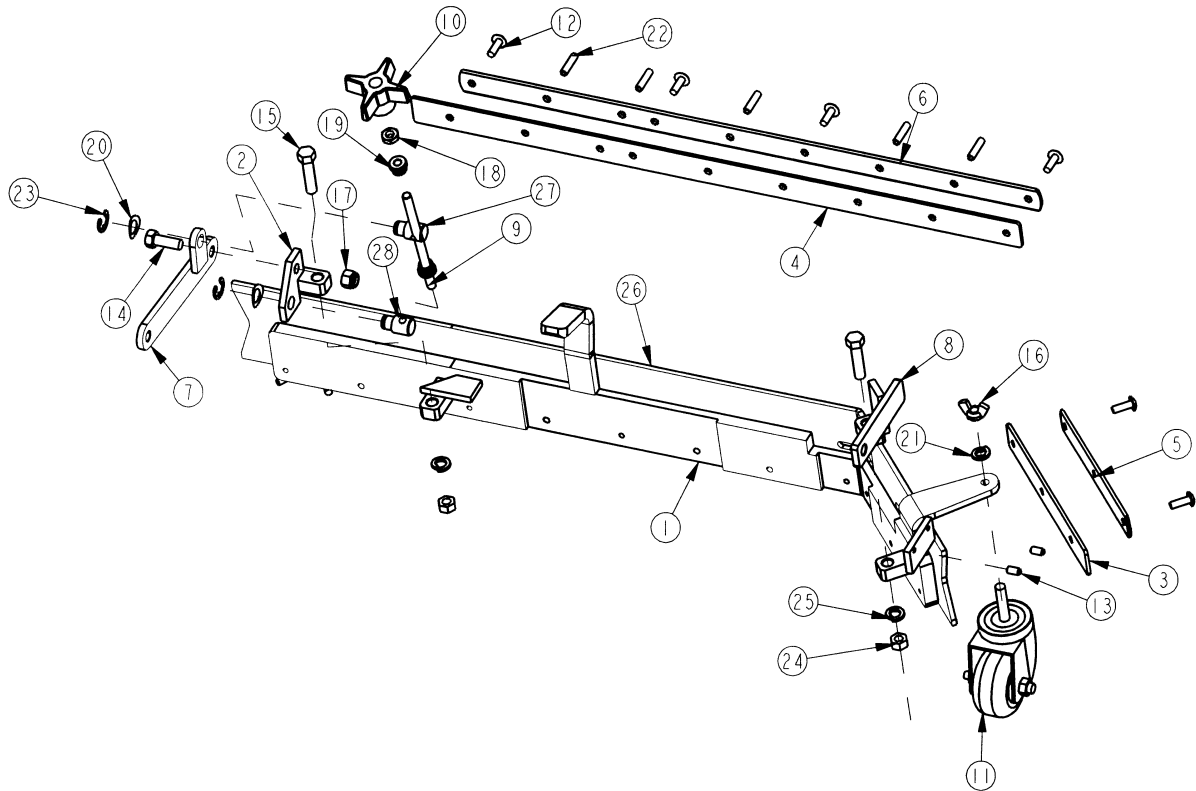

BILL OF MATERIAL 281912

ITEM	PART NO.	REQ'D	DESCRIPTION
1	281914	1	SIDE SQUEEGEE WMT, SCV RH
2	281924	1	FRONT MNT WMT RH, SIDE SQ
3	281932	1	BACKER BLADE, SIDE SQ SHORT
4	281933	1	BACKER BLADE, SIDE SQ LONG
5	281934	1	SHORT RETAINER, SIDE SQ
6	281935	1	LONG RETAINER, SIDE SQ
7	281937	1	FRONT LINK WMT RH, SIDE SQ
8	281944	1	REAR MNT WMT RH, SIDE SQ
9	281959	1	ADJUSMENT ROD
10	350139	1	KNOB, 4 ARM 5/16-18
11	430325	1	CASTER 3/8"-16 X 1.50"
12	710180	6	SCR-MC 1/4-20X.75 TR HD
13	711016	2	SCR-SK 1/4-20 X .50 - CUP PT. SET SCR
14	711242	1	BLT-HEX 3/8 -16X1.00 ZP
15	711243	2	SCR-HEX 3/8 -16X1.50 ZP
16	711367	1	NUT- WING 3/8-16 ST PL
17	711380	1	NUT-NYLOC 3/8-16 NUT
18	711420	1	NUT- HEX JAM 5/16-18 ST PL
19	711465	2	NUT, 5/16-18, BRASS KNURLED
20	711524	2	WSR-WAVE .52 X .87 X .01
21	711546	1	WSR-HELICAL 3/8
22	711658	6	ROLL PIN 1/4"X1.00"
23	711713	2	RETAINING RING - "E" TYPE EXT .500
24	712695	2	NUT-HEX 3/8-16 SS
25	712769	2	WSR-HELICAL 3/8 SS
26	281931-1	1	SIDE SQUEEGEE BLADE, LINATEX
27	762256PLT	1	NUT, ADJUSTING (LH)
28	762257PLT	1	NUT, ADJUSTING (RH)



**28" SIDE SQUEEGEE (LEFT SIDE)**

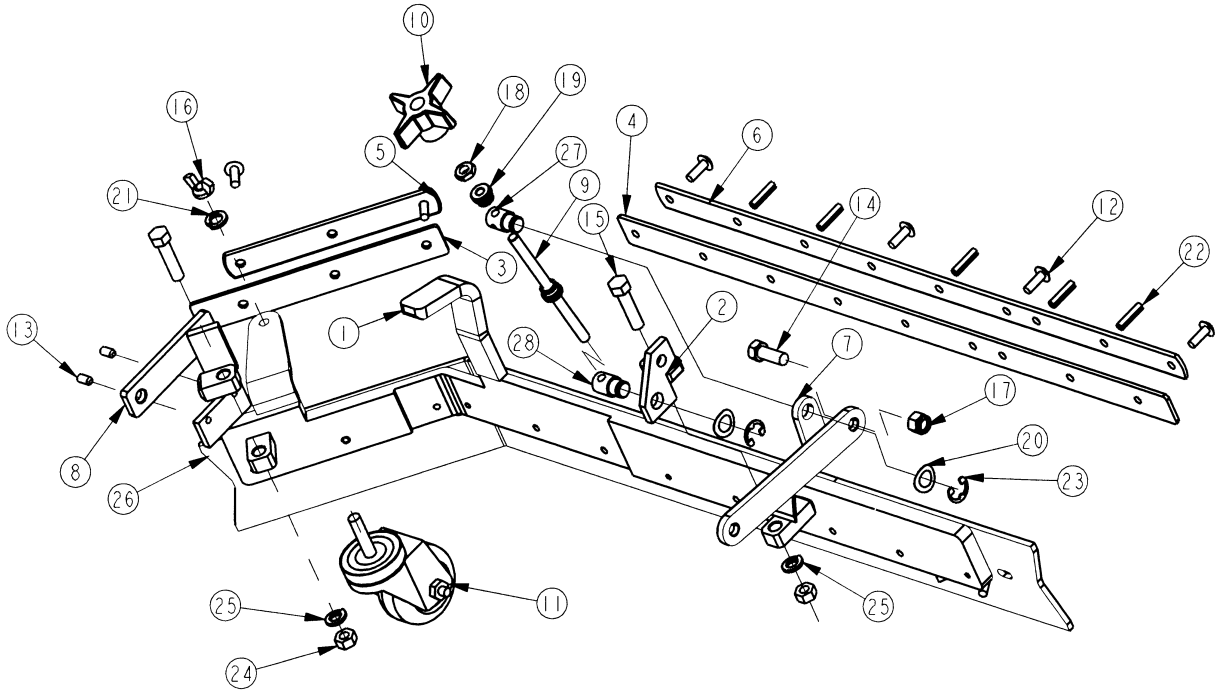

BILL OF MATERIAL 281911			
ITEM	PART NO.	REQ'D	DESCRIPTION
1	281913	1	SIDE SQUEEGEE WMT, SCV LH
2	281923	1	FRONT MNT WMT LH, SIDE SQ
3	281932	1	BACKER BLADE, SIDE SQ SHORT
4	281933	1	BACKER BLADE, SIDE SQ LONG
5	281934	1	SHORT RETAINER, SIDE SQ
6	281935	1	LONG RETAINER, SIDE SQ
7	281936	1	FRONT LINK WMT LH, SIDE SQ
8	281943	1	REAR MNT WMT LH, SIDE SQ
9	281959	1	ADJUSMENT ROD
10	350139	1	KNOB, 4 ARM 5/16-18
11	430325	1	CASTER 3/8"-16 X 1.50"
12	710180	6	SCR-MC 1/4-20X.75 TR HD
13	711016	2	SCR-SK 1/4-20 X .50 - CUP PT. SET SCR
14	711242	1	BLT-HEX 3/8 -16X1.00 ZP
15	711243	2	SCR-HEX 3/8 -16X1.50 ZP
16	711367	1	NUT- WING 3/8-16 ST PL
17	711380	1	NUT-NYLOC 3/8-16 NUT
18	711420	1	NUT- HEX JAM 5/16-18 ST PL
19	711485	2	NUT, 5/16-18, BRASS KNURLED
20	711524	2	WSR-WAVE .52 X .87 X .01
21	711546	1	WSR-HELICAL 3/8
22	711658	6	ROLL PIN 1/4"X1.00"
23	711713	2	RETAINING RING - "E" TYPE EXT .500
24	712695	2	NUT-HEX 3/8-16 SS
25	712769	2	WSR-HELICAL 3/8 SS
26	281931-1	1	SIDE SQUEEGEE BLADE, LINATEX
27	762256PLT	1	NUT, ADJUSTING (LH)
28	762257PLT	1	NUT, ADJUSTING (RH)

32" SIDE SQUEEGEE (RIGHT SIDE)

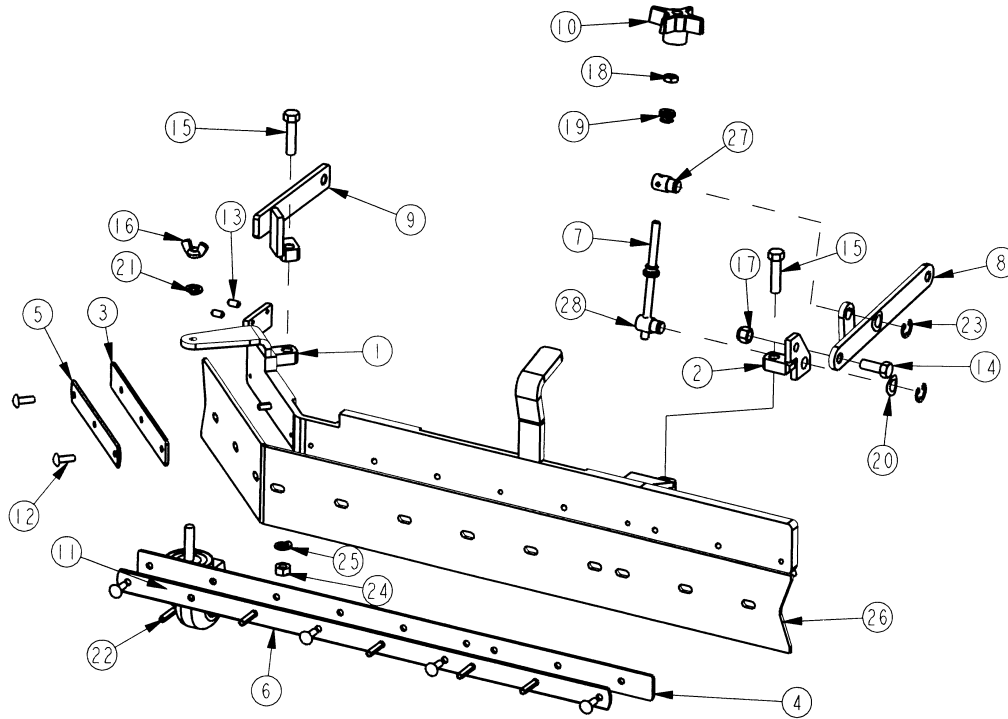

BILL OF MATERIAL 281962			
ITEM	PART NO.	REQ'D	DESCRIPTION
1	281914	1	SIDE SQUEEGEE WMT, SCV RH
2	281924	1	FRONT MNT WMT RH, SIDE SQ
3	281932	1	BACKER BLADE, SIDE SQ SHORT
4	281933	1	BACKER BLADE, SIDE SQ LONG
5	281934	1	SHORT RETAINER, SIDE SQ
6	281935	1	LONG RETAINER, SIDE SQ
7	281959	1	ADJUSMENT ROD
8	281987	1	FRONT LINK WMT RH, SIDE SQ 32"
9	281994	1	REAR MNT WMT LH, SIDE SQ 32"
10	350139	1	KNOB, 4 ARM 5/16-18
11	430325	1	CASTER 3/8"-16 X 1.50"
12	710180	6	SCR-MC 1/4-20X.75 TR HD
13	711016	2	SCR-SK 1/4-20 X .50 - CUP PT. SET SCR
14	711242	1	BLT-HEX 3/8 -16X1.00 ZP
15	711243	2	SCR-HEX 3/8 -16X1.50 ZP
16	711367	1	NUT- WING 3/8-16 ST PL
17	711380	1	NUT-NYLOC 3/8-16 NUT
18	711420	1	NUT- HEX JAM 5/16-18 ST PL
19	711465	2	NUT, 5/16-18, BRASS KNURLED
20	711524	2	WSR-WAVE .52 X .87 X .01
21	711546	1	WSR-HELICAL 3/8
22	711658	6	ROLL PIN 1/4"X1.00"
23	711713	2	RETAINING RING - "E" TYPE EXT .500
24	712695	2	NUT-HEX 3/8-16 SS
25	712769	2	WSR-HELICAL 3/8 SS
26	281931-1	1	SIDE SQUEEGEE BLADE, LINATEX
27	762256PLT	1	NUT, ADJUSTING (LH)
28	762257PLT	1	NUT, ADJUSTING (RH)

### 32" SIDE SQUEEGEE (LEFT SIDE)

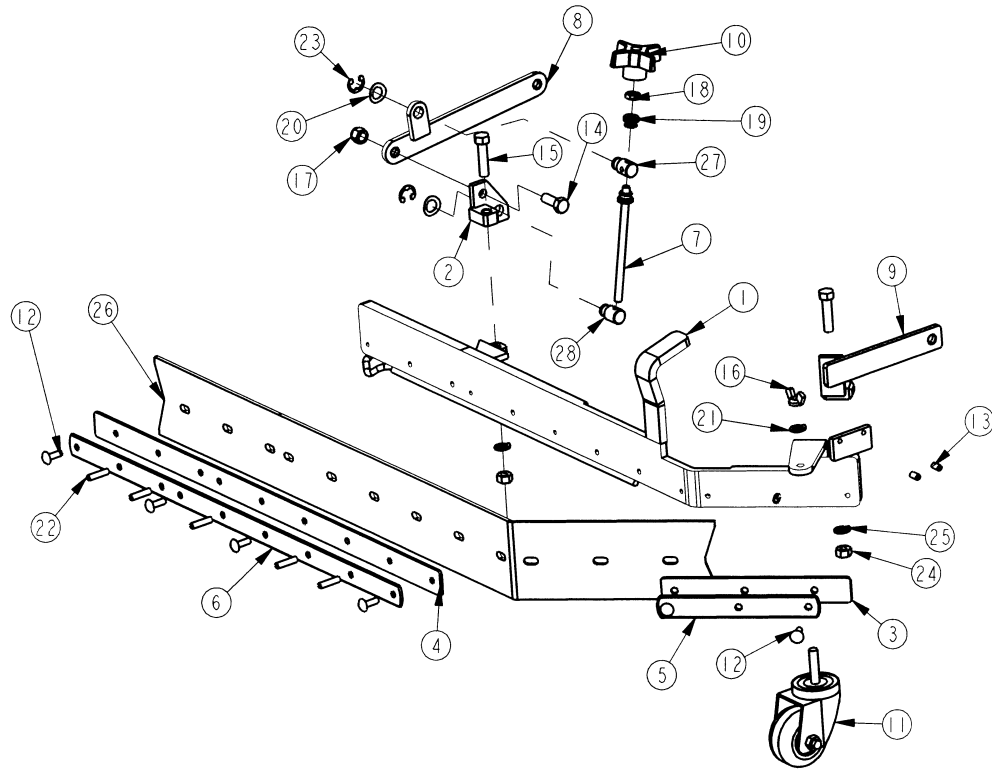

BILL OF MATERIAL 281961

ITEM	PART NO.	REQ'D	DESCRIPTION
1	281913	1	SIDE SQUEEGEE WMT, SCV LH
2	281923	1	FRONT MNT WMT LH, SIDE SQ
3	281932	1	BACKER BLADE, SIDE SQ SHORT
4	281933	1	BACKER BLADE, SIDE SQ LONG
5	281934	1	SHORT RETAINER, SIDE SQ
6	281935	1	LONG RETAINER, SIDE SQ
7	281959	1	ADJUSMENT ROD
8	281986	1	FRONT LINK WMT LH, SIDE SQ 32"
9	281993	1	REAR MNT WMT LH, SIDE SQ 32"
10	350139	1	KNOB, 4 ARM 5/16-18
11	430325	1	CASTER 3/8"-16 X 1.50"
12	710180	6	SCR-MC 1/4-20X.75 TR HD
13	711016	2	SCR-SK 1/4-20 X .50 - CUP PT. SET SCR
14	711242	1	BLT-HEX 3/8 -16X1.00 ZP
15	711243	2	SCR-HEX 3/8 -16X1.50 ZP
16	711367	1	NUT- WING 3/8-16 ST PL
17	711380	1	NUT-NYLOC 3/8-16 NUT
18	711420	1	NUT- HEX JAM 5/16-18 ST PL
19	711465	2	NUT, 5/16-18, BRASS KNURLED
20	711524	2	WSR-WAVE .52 X .87 X .01
21	711546	1	WSR-HELICAL 3/8
22	711658	6	ROLL PIN 1/4"X1.00"
23	711713	2	RETAINING RING - "E" TYPE EXT .500
24	712695	2	NUT-HEX 3/8-16 SS
25	712769	2	WSR-HELICAL 3/8 SS
26	281931-1	1	SIDE SQUEEGEE BLADE, LINATEX
27	762256PLT	1	NUT, ADJUSTING (LH)
28	762257PLT	1	NUT, ADJUSTING (RH)

# OFF AISLE WAND ASSEMBLY

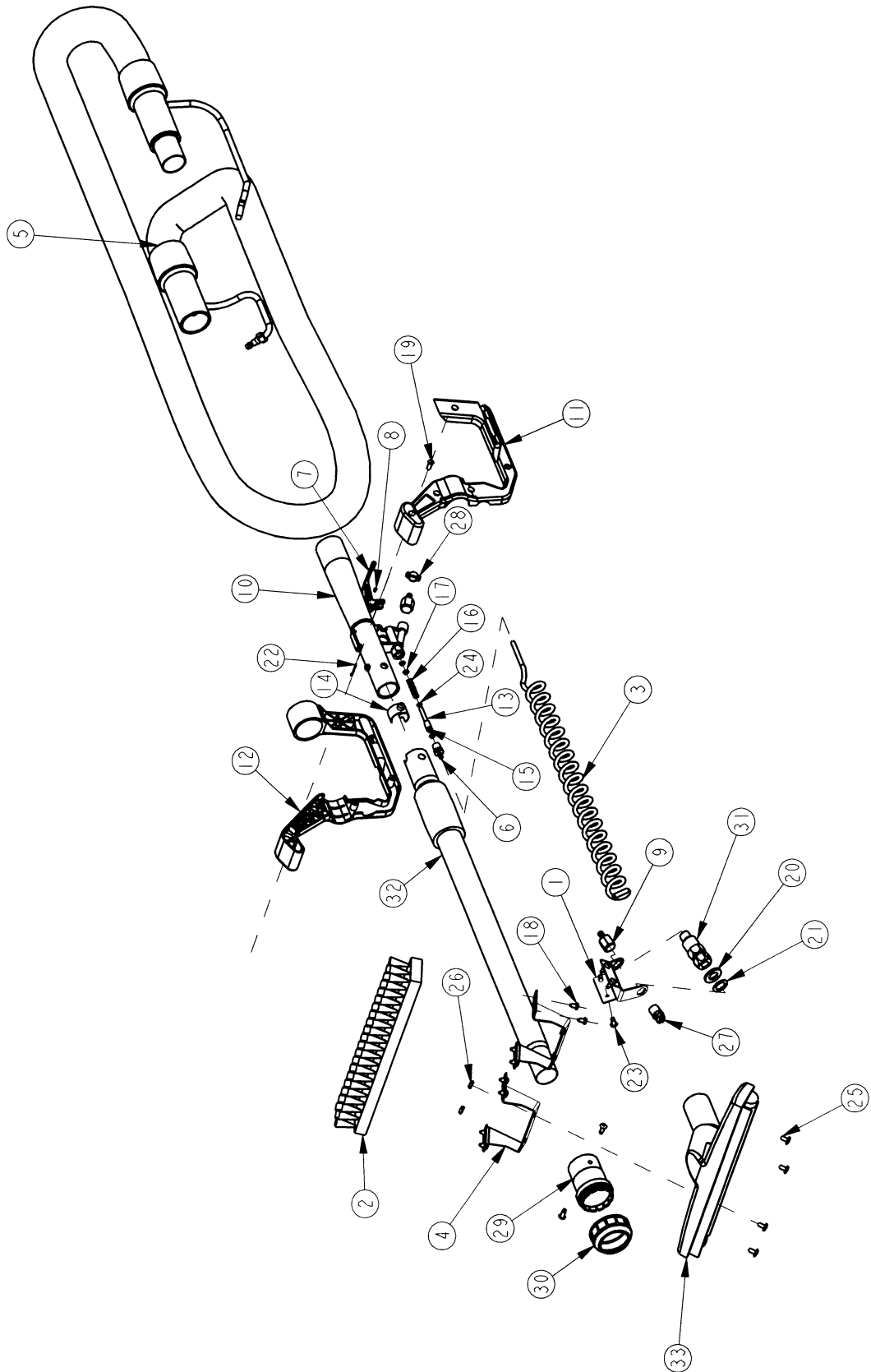

<i>BILL OF MATERIAL 281071</i>			
<i>ITEM</i>	<i>PART NO.</i>	<i>REQ'D</i>	<i>DESCRIPTION</i>
1	100004	1	SPRY JET BKT MC SCRB14GA
2	281044	1	BRUSH 12 X 1.75 X 1.12
3	281045	1	HOSE, SELF-RETRACTING SOLUTION
4	281049	2	BRUSH WAND BRACKET
5	281072	1	HOSE ASSEMBLY, SPRAY/VAC, 2800
6	350280	1	FITTING BRASS 1/8 MPT - 1/8 BARB
7	390053	1	TRIGGER SOL VALVE
8	390063	2	RD HD GRV STUD #2427
9	450218	2	FITTING, BRASS 1/4 FPT, 1/8 BARB
10	450256	1	PICKUP TUBE
11	450257	1	TRIGGER GUARD,LEFT
12	450258	1	TRIGGER GUARD,RIGHT
13	450261	1	VALVE STEM
14	450262	1	LOCKING BUTTON
15	450265	3	O-RING, BROWN
16	450267	1	SPRING SS LC-038D-13
17	450301	1	WASHER, NYLON
18	711116	8	SCR-ST-A 10 X .37 PL
19	711163	5	SCR-HI/LO #10-16 X 1/2
20	711579	1	WSR-FLAT .56 X 1.00 X .100
21	711594	1	WSR-FLAT .56 X .88 X .03
22	711803	1	COTTER PIN-HAIR
23	711903	6	RIVET-POP 3/16"
24	712323	1	WSR-FLT .195 X .281 X .03SS
25	712540	4	SCR-MC 10-24 X .37 SS TH
26	712638	4	NUT, HEX 10-24 SS NYLOC
27	829115	1	VEEJET 1/4"
28	830082	1	HOSE CLAMP 3/8
29	832278	1	1 1/4 WAND END COUPLING
30	832284	1	NUT FOR 832278/832285
31	833384	1	VALVE-BALL TYPE CHECK, 1/4" AB
32	270162MCH	1	TELESCOPING WAND (MACHINED)
33	281048MCH	1	SQUEEGEE NOZZLE - 12" (MACHINED)

**PLUMBING DIAGRAM**

**SCV 28/32  
PLUMBING  
DIAGRAM**

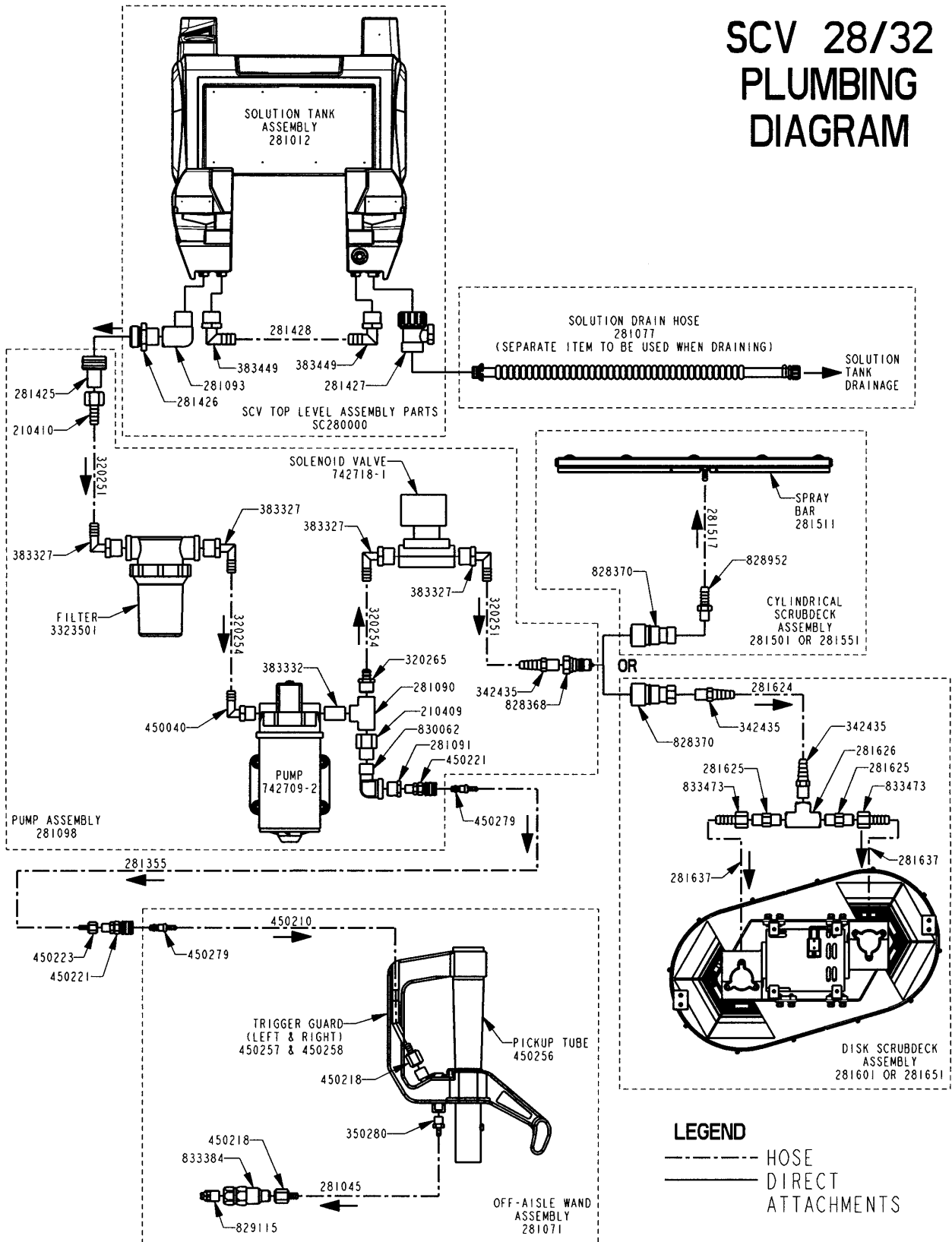

# WIRING DIAGRAMS

## POWER WIRING

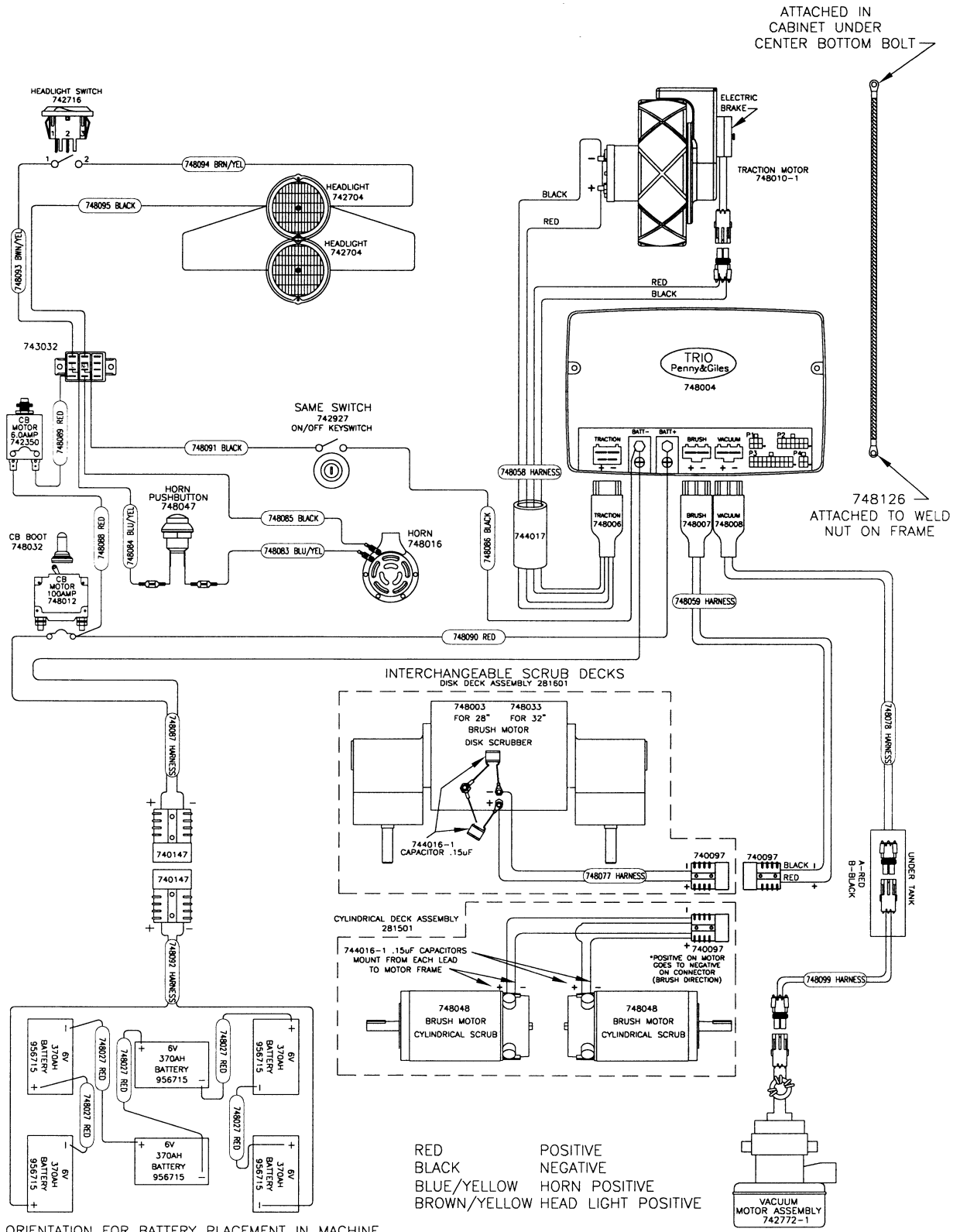

# INPUTS TO CONTROLLER

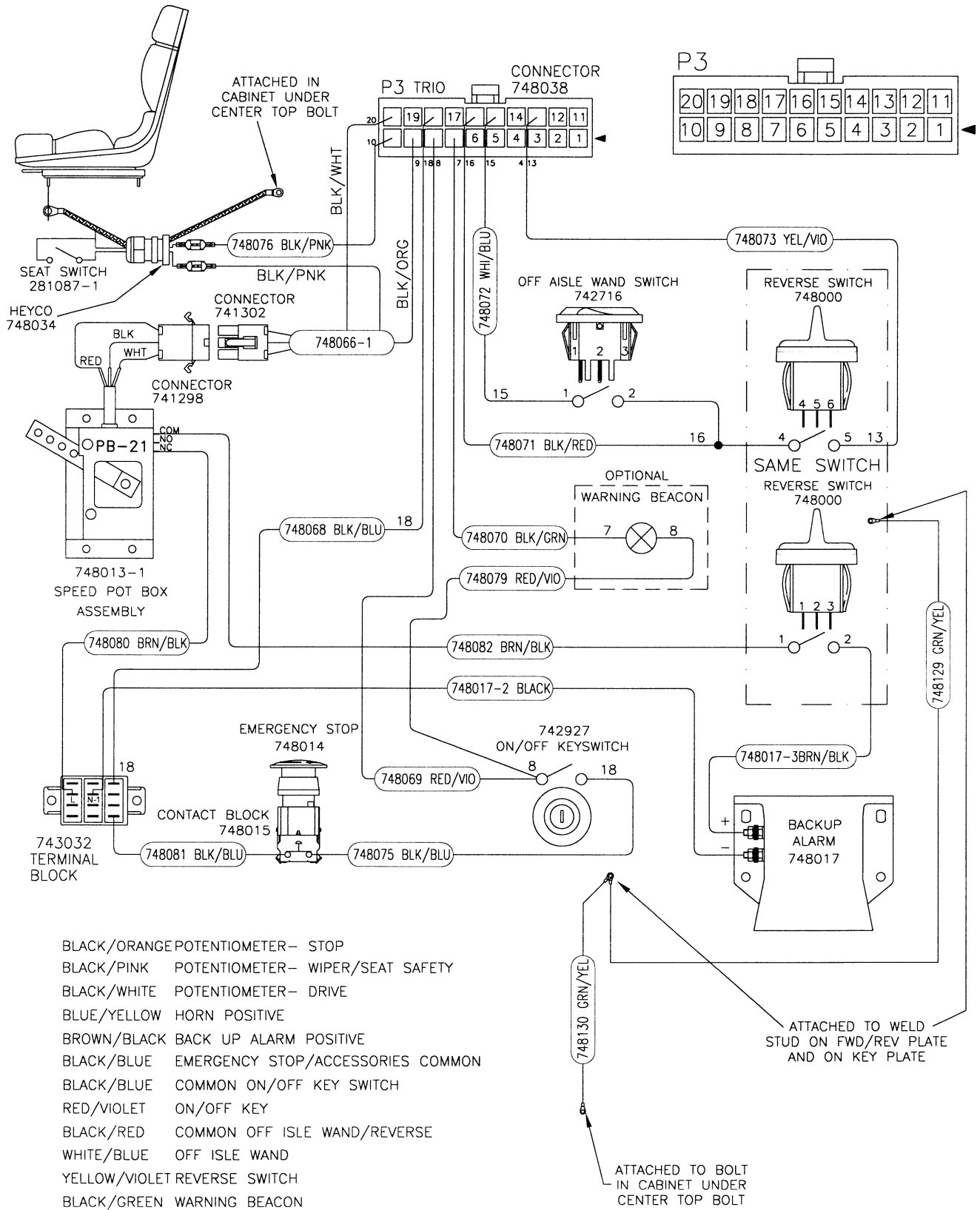



# OUTPUTS FROM CONTROLLER

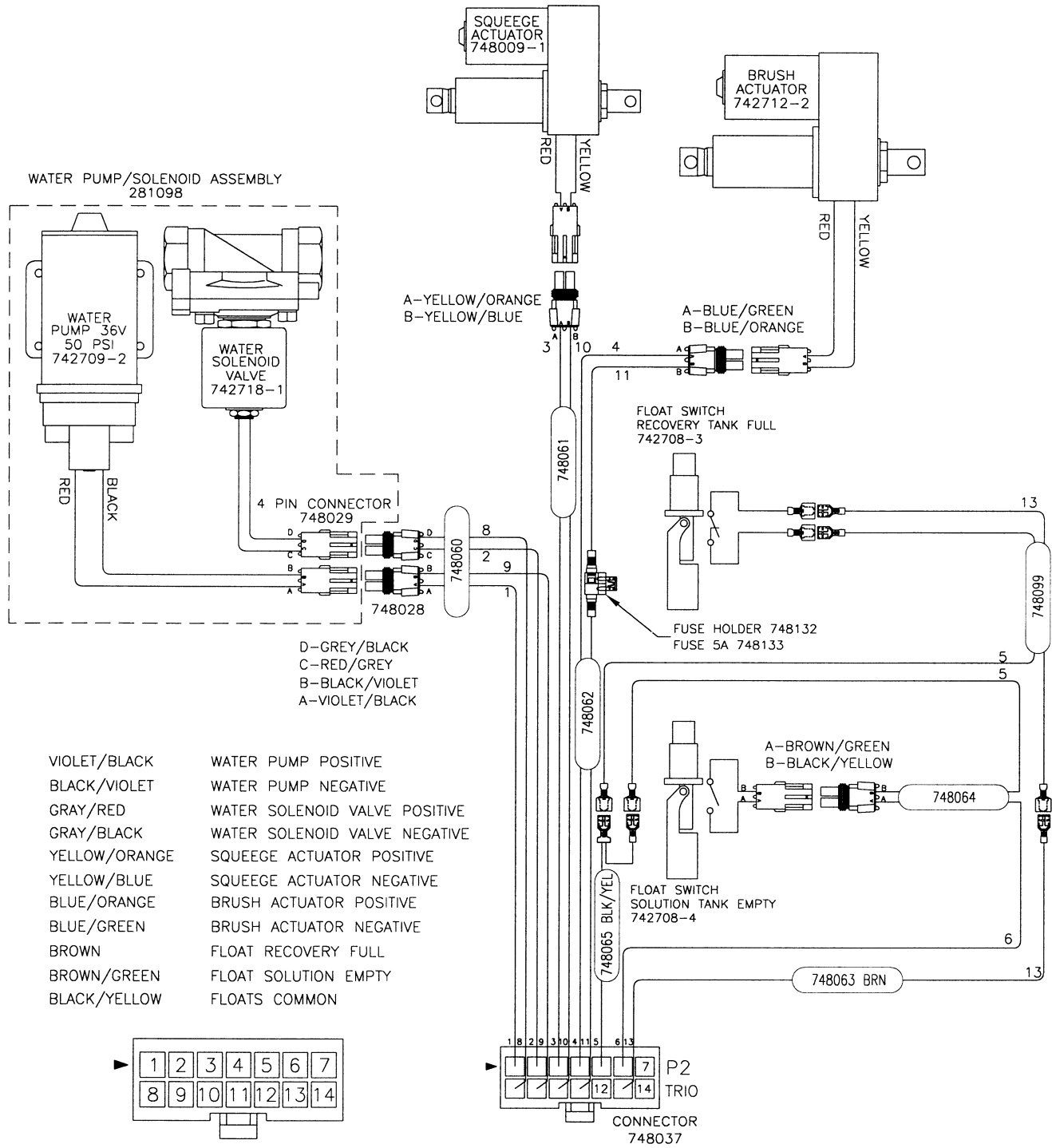

# KEYBOARD WIRING

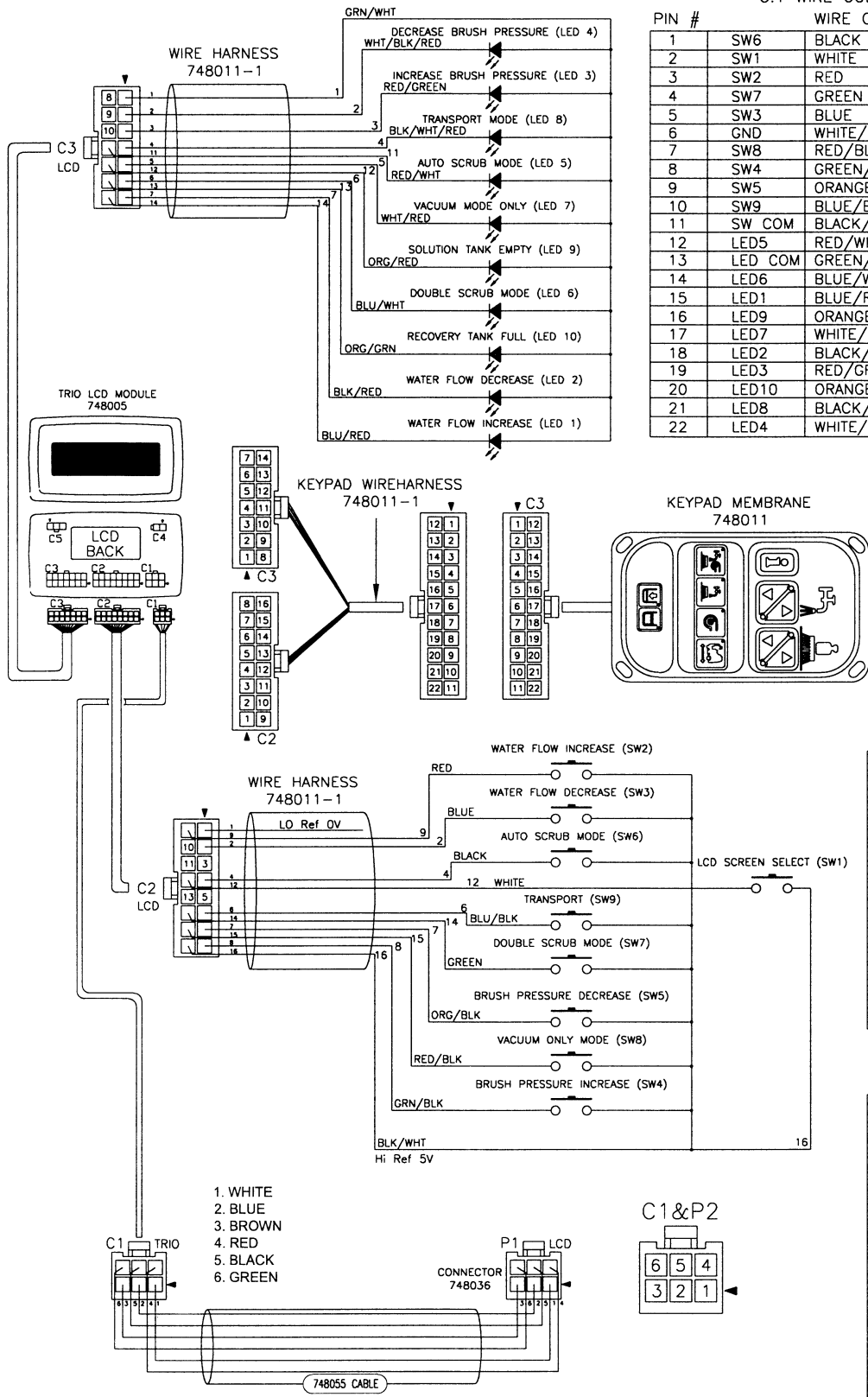

C:1 WIRE COLORS/POSITIONS

PIN #	WIRE COLOR	FUNCTION	
1	SW6	BLACK	AUTO SCRUB MODE
2	SW1	WHITE	LED SCREEN SELECT
3	SW2	RED	WATER FLOW INCREASE
4	SW7	GREEN	DOUBLE SCRUB MODE
5	SW3	BLUE	WATER FLOW DECREASE
6	GND	WHITE/BLACK	-
7	SW8	RED/BLACK	VACUUM ONLY MODE
8	SW4	GREEN/BLACK	BRUSH PRESSURE INCREASE
9	SW5	ORANGE/BLACK	BRUSH PRESSURE DECREASE
10	SW9	BLUE/BLACK	TRANSPORT MODE
11	SW COM	BLACK/WHITE	SWITCH COMMON
12	LED5	RED/WHITE	AUTO SCRUB
13	LED COM	GREEN/WHITE	COMMON ANODE
14	LED6	BLUE/WHITE	DOUBLE SCRUB
15	LED1	BLUE/RED	WATER FLOW INCREASE
16	LED9	ORANGE/RED	SOLUTION TANK EMPTY
17	LED7	WHITE/RED	VACUUM
18	LED2	BLACK/RED	WATER FLOW DECREASE
19	LED3	RED/GREEN	BRUSH PRESSURE INCREASE
20	LED10	ORANGE/GREEN	RECOVERY TANK FULL
21	LED8	BLACK/WHITE/RED	TRANSPORT MODE
22	LED4	WHITE/BLACK/RED	BRUSH PRESSURE DECREASE

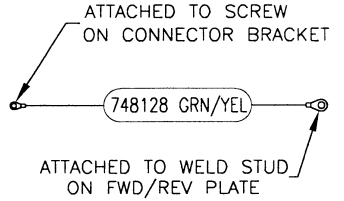

C:3 WIRE COLORS/POSITIONS

PIN #	WIRE COLOR	
1	LED COM	GREEN/WHITE
2	LED 4	WHT/BLK/RED
3	LED 3	RED/GREEN
4	LED 8	BLK/WHT/RED
5	LED 7	WHITE/RED
6	LED 6	BLUE/WHITE
7	LED 2	BLACK/RED
8	-	N.C.
9	-	N.C.
10	-	N.C.
11	LED 5	RED/WHITE
12	LED 9	ORANGE/RED
13	LED 10	ORANGE/GREEN
14	LED 1	BLUE/RED

C:2 WIRE COLORS/POSITIONS

PIN #	WIRE COLOR	
1	-	N.C.
2	SW3	BLUE
3	-	N.C.
4	SW6	BLACK
5	-	N.C.
6	SW9	BLUE/BLACK
7	SW5	ORANGE/BLACK
8	SW4	GREEN/BLACK
9	SW2	RED
10	-	N.C.
11	-	N.C.
12	SW1	WHITE
13	-	N.C.
14	SW7	GREEN
15	SW8	RED/BLACK
16	SW COM	BLACK/WHITE

# MACHINE SCHEMATIC

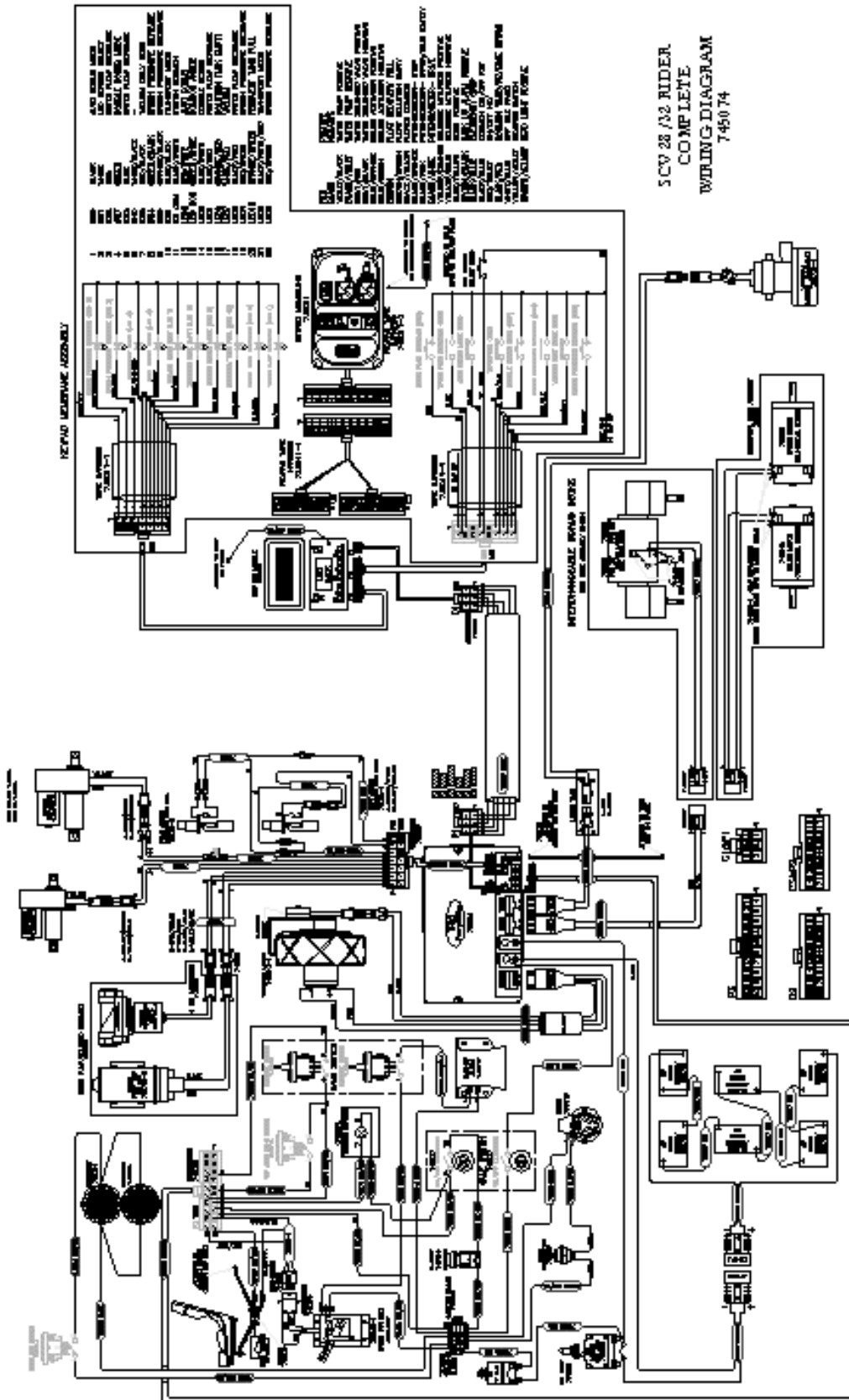

## LIMITED WARRANTY

Minuteman Powerboss, Inc. warrants to the original purchaser/user that this product is free from defects in workmanship and materials under normal use and service for a period of three years from date of purchase. In addition, Minuteman Powerboss, Inc. will, at its option, honor labor warranty claims for the first 12 months from date of sale, provided such claims are submitted through and approved by factory authorized repair stations. Minuteman Powerboss, Inc. will, at its option, repair or replace without charge, except for transportation costs, parts that fail under normal use and service when operated and maintained in accordance with the applicable operation and instruction manuals.

This warranty does not apply to normal wear, or to items whose life is dependent on their use and care, such as belts, cords, switches, hoses, rubber parts, electrical motor components or adjustments. Parts not manufactured by Minuteman Powerboss, Inc. such as engines, batteries, battery chargers, hydraulic pumps, and tires are covered by and subject to the warranties and/or guarantees of their manufacturers. Please contact Minuteman Powerboss, Inc. for procedures in warranty claims against these manufacturers.

**Special warning to purchaser** -- Use of replacement filters and/or prefilters not manufactured by Minuteman Powerboss, Inc. or its designated licensees, will void all warranties expressed or implied.

A potential health hazard exists without exact original equipment replacement.

All warranted items become the sole property of Minuteman Powerboss, Inc. or its original manufacturer, whichever the case may be.

Minuteman Powerboss, Inc. disclaims any implied warranty, including the warranty of merchantability and the warranty of fitness for a particular purpose. Minuteman Powerboss, Inc. assumes no responsibility for any special, incidental or consequential damages.

This limited warranty is applicable only in the U.S.A. and Canada, and is extended only to the original user/purchaser of this product. Customers outside the U.S.A. and Canada should contact their local distributor for export warranty policies. Minuteman Powerboss, Inc. is not responsible for costs or repairs performed by persons other than those specifically authorized by Minuteman Powerboss, Inc. This warranty does not apply to damage from transportation, alterations by unauthorized persons, misuse or abuse of the equipment, use of non-compatible chemicals, or damage to property, or loss of income due to malfunctions of the product.

If a difficulty develops with this machine, you should contact the dealer from whom it was purchased.

This warranty gives you specific legal rights, and you may have other rights which vary from state to state. Some states do not allow the exclusion or limitation of special, incidental or consequential damages, or limitations on how long an implied warranty lasts, so the above exclusions and limitations may not apply to you.

**Minuteman<sup>®</sup>**  
**PowerBoss<sup>®</sup>**

**World Headquarters**  
Minuteman Powerboss, Inc.  
175 Anderson St  
Aberdeen NC 28315

(910) 944-2168  
FAX (910) 944-7409

Minuteman Powerboss Canada, Inc.  
2210 Drew Road  
Mississauga, Ontario  
L5S 1B1

(905) 673-3222  
FAX (905) 673-5161

988314  
Printed in U.S.A.  
07/03